

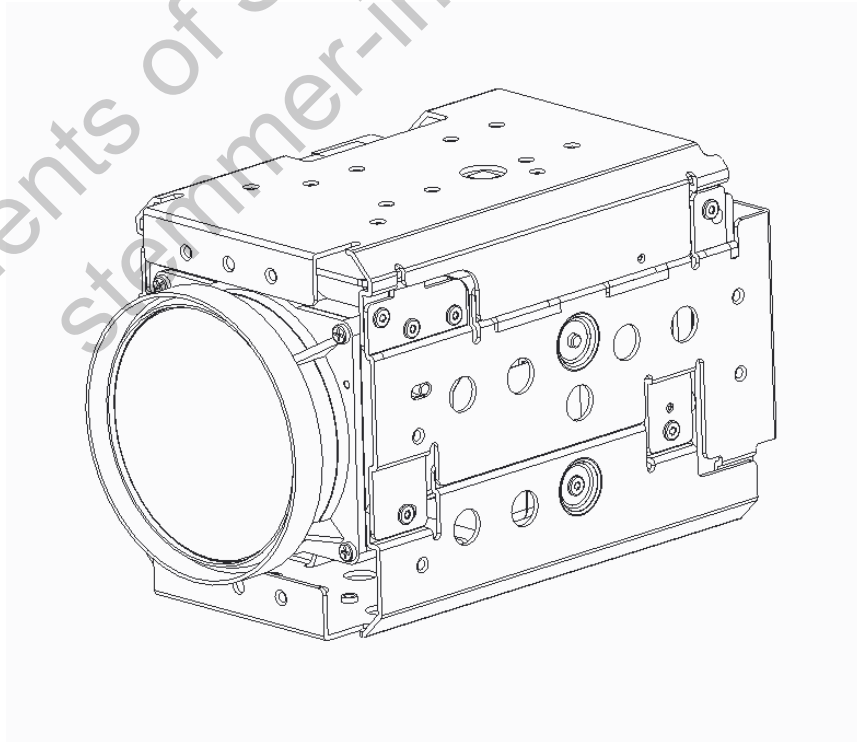

skoopia



skoopia 21Z30S



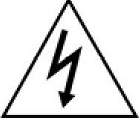

Revision History

Version	Date	Description	Remarks
1.00		First Release	

	CAUTION RISK OF ELECTRIC SHOCK DO NOT OPEN	
CAUTION : TO REDUCE THE RISK OF ELECTRIC SHOCK, DO NOT REMOVE COVER. ACCESSORIES SOLD SEPARATELY. CONTACT QUALIFIED SERVICE PERSONNEL FOR INFORMATION ACCESSIBLE ACCESSORIES.		

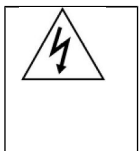

The lightning arrowhead symbol in a triangle means to watch out for live wires that might cause an electrical shock.



The exclamation symbol in a triangle indicates an important operational and service instruction.

WARNING

Please note that the user is liable for any incidents in operating the unit if it is altered or modified without manufacturer's approval.

CAUTION

To prevent electric shock and risk of fire hazards:
Do not use power sources except for that specified.



Do not expose this appliance to rain or moisture.

This installation should be made by a qualified service person and should abide to all local codes.

Compliments of STEMMER IMAGING USA
stemmer-imagingusa.com



1. SAFETY INSTRUCTIONS

Read Instructions

Read all of the safety and operating instructions before using the product.

Retain Instructions

Save this instructions for later use.

Cleaning

Unplug this appliance form wall outlet before cleaning. Do not use liquid cleaners or aerosol cleaners. Use a damp cloth for cleaning.

Water and Moisture.

Do not use this product near water or moisture.(For example. Near a bathtub, wash bowl, kitchen sink, or laundry tub, in a wet basement, or near swimming pool, etc.)

Installation

Do not place this product on an unstable cart, stand, or table. The product may fall causing serious injury to a child or adult, and damage to the product. Use only with a cart or stand recommended by the manufacturer, or sold with the product. Mounting should follow the manufacturer's instructions, and should use a mounting accessory recommended by manufacturer.

Power source

This Product should be operated only form the type of power source indicated on marking label.

If you are not sure of the type of power supplied to your home, consult your dealer or local power company



2. PRECAUTIONS

- **Do not use the camera in extreme temperature conditions.**

- **Do not use or store the camera in humid environment**

It may cause poor image quality.

- **Do not use the camera in unstable lighting conditions.**

Inconsistent lighting or flickering may cause poor image.

- **Never use the camera close to gas or oil leak.**

It may not operate properly.

- **Do not disassemble the camera.**

There is no user serviceable part inside.

- **Do not drop the camera or apply force on it.**

It may cause a malfunction.

- **Never face the camera to strong light for long periods of time.**

It may damage the CMOS sensor.

- **Do not expose the camera to rain or any types of liquid**

If wet, wipe the moisture out immediately.

Liquids can contain minerals that corrode the electronic components.



When this camera is installed near wireless communication devices that emits strong electromagnetic field, irregularity such as noise may appear in the image.



INDEX

1. SAFETY INSTRUCTIONS.....	4
2. PRECAUTIONS.....	5
3. FEATURES.....	7
4. SPECIFICATION.....	9
5. OPERATING CAMERA.....	10
5.1. Camera OSD menu.....	10
5.2. WHITE BALANCE.....	12
5.3. EXPOSURE.....	13
5.4. FOCUS.....	13
5.5. BACK LIGHT.....	14
5.6. IMAGE CONTROL.....	14
5.7. DISPLAY CONTROL.....	15
5.8. SYSTEM SETUP.....	16
5.9. RESET.....	16
6. Video Output.....	16
6.1. Video Mode.....	16
6.2. Output Timing Chart(1920x1080p@30/60/29.97/59.94).....	18
6.3. Output Timing Chart(1920x1080p@25/50).....	19
6.4. Output Timing Chart(1920x1080i@60/59.94).....	20
6.5. Output Timing Chart(1920x1080i@50).....	21
6.6. Output Timing Chart(1280x720p@60/59.94).....	22
6.7. Output Timing Chart(1280x720p@50).....	23
6.8. Output Timing Chart(1280x720p@30/29.97).....	24
6.9. Output Timing Chart(1280x720p@25).....	25
6.10. Video Data Start/Stop Format.....	26
7. Camera Interface.....	27
7.1. Camera Interface.....	27
7.2. LVDS Interface.....	29
7.3. Application of recommended circuit Camera Reception.....	31
7.4. Key Application recommended circuit.....	33
8. Dimensions.....	34
APPENDIX A.....	35
APPENDIX B.....	63



3. FEATURES

- 1/2.8 inch Sony STARVIS CMOS image sensor (approx. 2.1 million effective pixels)

Progressive scan

- WDR (Wide Dynamic Range) Function

- Video signals output

HD LVDS : Digital ITU-R BT.1120 - YcbCr4:2:2 16bits

Analog : SD CVBS (NTSC/ PAL), 1.0Vp-p 75Ω, Composite

HD SDI:

SMPTE 292M(1.485Gbps)	1920x1080p@25/30/29.97
	1920x1080i@50/60/59.94
	1280x720p@25/30/50/60/29.97/59.94
SMPTE 424M(2.97Gbps)	1920x1080p@50/60/59.94

- 30x optical zoom lens with F1.5 aperture(optical zoom + digital zoom = 360x)

- Day and Night

ICR for infrared cut filter

- Privacy Zone Masking function

- Communications protocol supported to be controlled remotely

-SONY-VISCA, PELCO-P/D, etc

- High performance functions

-3D-DNR (Digital Noise Reduction)

-BLC (Back Light Compensation)

-Motion Detection

-Defog

-Image flip

-HLC (High Light Compensation)



4. SPECIFICATION

Compliments of STEMMER IMAGING USA
stemmer-imagingusa.com



21Z30L		SPECIFICATIONS	
Sensor	Image Sensor	1/2.8" Progressive CMOS (2.1 mega)	
	Scanning System	16:9 Progressive	
	Sync. System	Internal	
	Effective Pixel	1920(H) x 1080(V)	
	Min. Illumination	0.05Lux (Day), 0.005Lux (Night), 0.0005Lux(DSS on)	
	Horizontal Resolution	1000 TVL	
Optics	Lens	30x optical Zoom, F=4.7~141 mm, F1.5(Wide) ~ F4.0(Tele)	
	Zoom	30x optical zoom + 12x digital zoom = 360x	
	Focus	Near/Far, Auto/Manual/One Push	
	Angle of View(H)	60.5 degrees (wide end), 2.3 degrees (tele end)	
	Min. working distance	T.B.D	
Functions	Back Light Compensation	WDR, BLC, HLC(High Light compensation)	
	Exposure	Auto / Manual	
	White Balance	Auto(3,000°K~8,000°K) / ATW(1,900°K~11,000°K) / Manual	
	Day & Night System	AGC / TDN(ICR)	
	Electronic Shutter	NTSC: 1/30~1/10000, PAL: 1/25~1/10000, DSS(~ 1/1sec)	
	Functions	Privacy Mask, Image Mirror, 3DNR, Flicker-less, Sharpness, Defog, DIS(Digital Image stabilizer), NegArt, Freeze	
Video Outputs	Digital Output (LVDS) ITU-R BT.1120 YcbCr4:2:2 16bits	1920x1080p@25/30/50/60/29.97/59.94 1920x1080i@50/60/59.94 1280x720p@25/30/50/60/29.97/59.94	
	SDI	SMPTE 292M(1.485Gbps): 1080p@25/30/29.97 1080i@50/60/59.94 720p@25/30/29.97/50/60/59.94 SMPTE 424M(2.97Gbps): 1080p@50/60/59.94	
	CVBS	Analog Composite(1V ± 0.2 Vp-p) NTSC/PAL	
	Control Interface	UART(5V level)	PELCO-P/D, SONY-VISCA protocol
			8bits data, 1 stop bit, no parity, 2400~115200bps
General	Operation Temperature	T.B.D	
	Power Input	12VDC (7V to 15VDC)	
	Power consumption	Max 5W (3.2W Lens inactive, 3.9W Lens active)	
	Mass	Approx. 250g (8.8 oz.)	
	Dimensions	96.6(D) x 50.0(W) x 60.0(H) mm	



5. OPERATING CAMERA

5.1. Camera OSD menu

WB CONTROL	MODE	AWB / ATW / PUSH / INDOOR / OUTDOOR / MANUAL		
	PUSH			
	RED	0 ~ 100		
	BLUE	0 ~ 100		
AE CONTROL	MODE	AUTO/SHUT PRI/IRIS PRI/AGC PRI/BRIGHT/MANUAL		
	SHUT	/ 30/60/90/100/125/180/250/350/500/725/1000/1500/2K/3 K/4K/6K/10K		
	IRIS	F1.6 ~ F16		
	AGC	0 dB ~		
	AGC LIMIT	0 ~ 15		
	SENS UP	OFF ~ X15		
	EXP COMP	0 ~ 14		
	FLICKERLESS	OFF/ AUTO/ ON		
	FOCUS CONTROL	FOCUS MODE	AUTO/ MANUAL	
	PUSH	PRESS OK		
	AF MODE	NORMAL/ INTERVAL/ ZOOM TRIG		
	WIDE LIMIT	X1 ~X29		
	TELE LIMIT	X2 ~X30		
	DZOOM	OFF/ ON		
	ZOOM SPEED	0 ~ 7		
	NEAR LIMIT	0.5M/ 1M/ 2M/ 3M/ 5M/ 10M/ 30M		
	AF INTERVAL	0 ~ 255		
BACK LIGHT	BACKLIGHT	BLC	LEVEL	0~255
			DISPLAY	OFF/ ON
			WIDTH	0~48
			HEIGHT	0~33
			MOVE HOR	0~48
			MOVE VER	0~33
	HLM	AREA DISPLAY	OFF/ ON	
		LEVEL	0~20	
		BLACK MASK	OFF/ ON	
		WIDTH	0~48	
		HEIGHT	0~33	
		MOVE HOR	0~48	
	SPOT AE	DISPLAY	OFF/ ON	
		WIDTH	0~48	
		HEIGHT	0~33	
		MOVE HOR	0~48	
		MOVE VER	0~33	



	WDR	OFF/ ON		
	DWDR	STRENGTH	0 ~ 16	
		SATURATION	0 ~ 16	
		LOCAL RATIO	0 ~ 16	
		SAT. SYNC	OFF/ ON	
		AUTO LEVEL	LOW/ MID/ HIGH	
	DEFOG	STRENGTH	0 ~ 16	
		THRESHOLD	0 ~ 3	
		AUTO LEVEL	LOW/ MID/ HIGH	
IMAGE CONTROL	COLOR LEVEL	0 ~ 20		
	SHARPNESS	0 ~ 20		
	CONTRAST	0 ~ 20		
	HUE	-10 ~ 0 ~ 10		
	IMAGE EFFECT	OFF/ NEGA/ GRAY		
	IMAGE FLIP	OFF/MIRROR/V-FLIP/ROTATION		
	DNR	MODE	OFF/ 2D/ 3D/ 2D+3D	
		3DNR LEVEL	LOW/MID/HIGH/AUTO	
		2DNR LEVEL	LOW/MID/HIGH/AUTO	
		APERTURE	0~4	
	GAMMA	DEFAULT/1.0 ~ 0.4		
	GAMMA OFFSET	-64 ~ 64		
	COLOR SUPPRESS	OFF/ LOW/ MID/ HIGH		
LENS SHADING	OFF/ ON			
DISPLAY	DAY/NIGHT	MODE	AUTO/ DAY/ NIGHT	
		DELAY [SEC]	0 ~ 60	
		D->N LEVEL	0 ~ 28	
		N->D LEVEL	0 ~ 27	
		NIGHT COLOR	OFF/ ON	
		COLOR BURST	OFF/ ON	
	CAM TITLE	OFF/ ON		
	ZOOM MAG	OFF/ ON		
	PRIVACY	MODE	OFF/ ON	
		TYPE	SQUARE/ POLYGON	
		MASK NO.	MASK1 ~ MASK8	
		DISPLAY	OFF/ ON	
		COLOR	BLK/WHT/GRN/BLE/RED/CYAN/MAG/YEL/G RAY1~6,MOSAIC	
		POLY SELECT	L-TOP/ R-TOP/ L-BOT/ R-BOT	
		POSITION HOR	0~255	
		POSITION VER	0~216	



		WIDTH	0~120
		HEIGHT	0~68
	MOTION	AREA	1 ~ 4
		AREA ACTIVE	OFF/ ON
		AREA DISPLAY	OFF/ ON
		SIZE POSITION	
		SENSITIVITY	0 ~ 40
		MOTION VIEW	OFF/ ON
	DEFECT PIXEL	OFF/ON/STATIC/FIXED	
	IMAGE STABILIZER	OFF/ ON	
SYSTEM SETUP	CAM ID	1 ~ 255	
	ID DISPLAY	OFF/ON	
	BAUDRATE	2400/4800/9600/19200/38400/115200	
	OUTPUT FORMAT	1080P60/50/30/25/ 1080I60/50 720P/60/50/30/25	
	VER.		
RESET	MODE	FACTORY / USER	
EXIT			

5.2. WHITE BALANCE

AWB : Color temperature is automatically adjusted to 3,000°K ~ 8,000°K

ATW : Color temperature is automatically adjusted to 1,900°K ~ 11,000°K

INDOOR : Color temperature is manually adjusted to indoor

OUTDOOR : Color temperature is manually adjusted to outdoor

MANUAL WB : Color Temperature is manually adjustable to adjusting value.

RED and BLUE gain can be changed for better pictures.

PUSH WB : Color Temperature is manually adjustable to adjusting value.

The One Push White Balance mode is a fixed white balance mode that may be automatically readjusted

only at One Push Trigger, while the camera is directed at a piece of white paper to obtain the optimum

state under current illumination.

One Push White Balance data is lost when the power is turned off. If the power is turned off, reset One Push White Balance.



5.3. EXPOSURE

MODE :

AUTO - Iris, gain and shutter can be controlled automatically.

MANUAL - Manual control of Iris, gain and shutter.

SHUTTER Priority - Manual control of shutter. Iris and gain can be controlled automatically.

IRIS Priority - Manual control of IRIS. Shutter and gain can be controlled automatically.

BRIGHT - Iris and gain can be controlled by control of brightness

SHUTTER :

Auto - Shutter controls exposure automatically when iris is manual.

Manual - Shutter is fixed, and gives the exposure control priority to other resources.

IRIS :

Auto - Iris controls exposure automatically, and shutter is fixed.

Manual - Iris is fixed, and gives the exposure control priority to other resources.

AGC LIMIT: To select maximum automatic gain limit.

Camera raises up gain to selected gain limit when dark conditions.

EXP COMP :

The exposure compensation function adjusts gain and iris, to keep a brightness level.

SENS UP :

Minimum slow shutter limit is down to 1/1 second.

The value means seconds.

Camera make Shutter speed longer to selected shutter limit when dark conditions.

FLICKERLESS :

This function used only for specific country to remove light flickering when light appears to flutter.

5.4. FOCUS

The camera employs a 30x optical zoom lens combined with a 12x digital zoom function. This camera

allows you to zoom up to 360x.

Optical 30x, f = 4.7 mm to 141 mm (F 1.5 to F 4.0)

Digital Zoom 12x : enlarges of the subject

7 levels of zoom speed

FOCUS MODE :

Auto mode automatically adjusts the focus position.



Manual mode adjusts the focus position by manual and when zoom is changed.

AF MODE :

Normal mode automatically adjusts the focus position.

Interval mode adjusts the focus position at time interval and when zoom is changed.

Zoom trig mode adjusts the focus position when zoom is changed.

ONE PUSH : When One Push AF command is sent, camera becomes Auto Focus mode to adjust focus

position for a while. After it stops, mode becomes that for Manual focus mode.

NEAR LIMIT : Priority for focusing distance. The lens moves to adjust the focus from the distance.

5.5. BACK LIGHT

BACKLIGHT : When background is too bright behind the object, the BLC make clearer object.

HLM - Highlight suppression reduce too bright light by masking it with specific color.

WDR : When background is too bright behind the object, the WDR make clearer images of the

background as well as the object. Wide dynamic range produce images that combining long-exposure

signals (normal shutter) with the signals of the high-intensity portions obtained with a short exposure

(high-speed shutter).

DWDR : Dark areas of image brightness correction.

DEFOG : This function affects the effect of fog removal. Furthermore, it improves visibility by removing fog, clouds, smoke, and dust.

5.6. IMAGE CONTROL

COLOR LEVEL

Color level is the colorfulness of a color relative to its own brightness.

SHARPNESS

As you increase this value, the picture outline becomes stronger and clearer. Adjust this value

appropriately depending on the sharpness of the picture.

IMAGE FLIP

Video output is set horizontally vertically, and rotate.



DNR

2D/3DNR reduces video noises at low ambient light.

SHADING

Image center and the outskirts of brightness difference correction

GAMMA

Video out brightness correction function

COLOR SUPPRESS

Color suppress reduces color noise in low illumination conditions.

5.7. DISPLAY CONTROL

DAY / NIGHT

- **AUTO** : Auto day/night mode automatically switches between Color and Black/White depending on darkness. ICR(IR cut) filter is removed when it switches to black/white.
D->N level - This level is threshold for switching day to night.
N->D level - This level is threshold for switching night to day.
Delay(Dwell) time - Checking time for condition of light to confirm changing to Color and Black/White.
Color Burst - Color burst off makes that the color burst is removed when ICR switches to black/white.
- **DAY** : The camera keeps color mode constantly.
- **NIGHT** : The camera keeps black/white mode constantly.

CAM TITLE

OSD character camera name settings..

ZOOM MAGNIFICATION

Display the Zoom scale.

PRIVACY

It is possible to set the size of the area and a video Mask.

MOTION

Video zone settings and sensitivity can be set.

IMAGE STABILIZER

This function reduces image blurring associated with the motion of a camera.



5.8. SYSTEM SETUP

CAM ID

The camera is capable of recognizing number setting up 1 to 255.

BAUDRATE

Camera communication bit rate.

OUTPUT FORMAT

Video output specification set(NTSC/PAL) and video size settings(1080p/720p)

5.9. RESET

Camera returns into initial value except ID and baudrate.

Compliments of STEMMER IMAGING USA
stemmer-imagingusa.com



6. Video Output

6.1. Video Mode

Video output :

1080p - 2200x1125@30/60/29.97/59.94 fps, 2640x1125@25/50fps

1080i - 2200x562(563)@60/59.94 fps, 2640x562(563)@50fps

720p - 1650x750@60/59.94 fps, 1980x750@50fps, 3300x750@30/29.97 fps,
3960x750@25fps

Pixel clock : 74.25MHz, 148.5MHz

YCbCr422 16bits data(BT.1120 format), HD, VD

Active area (1920 x 1080)

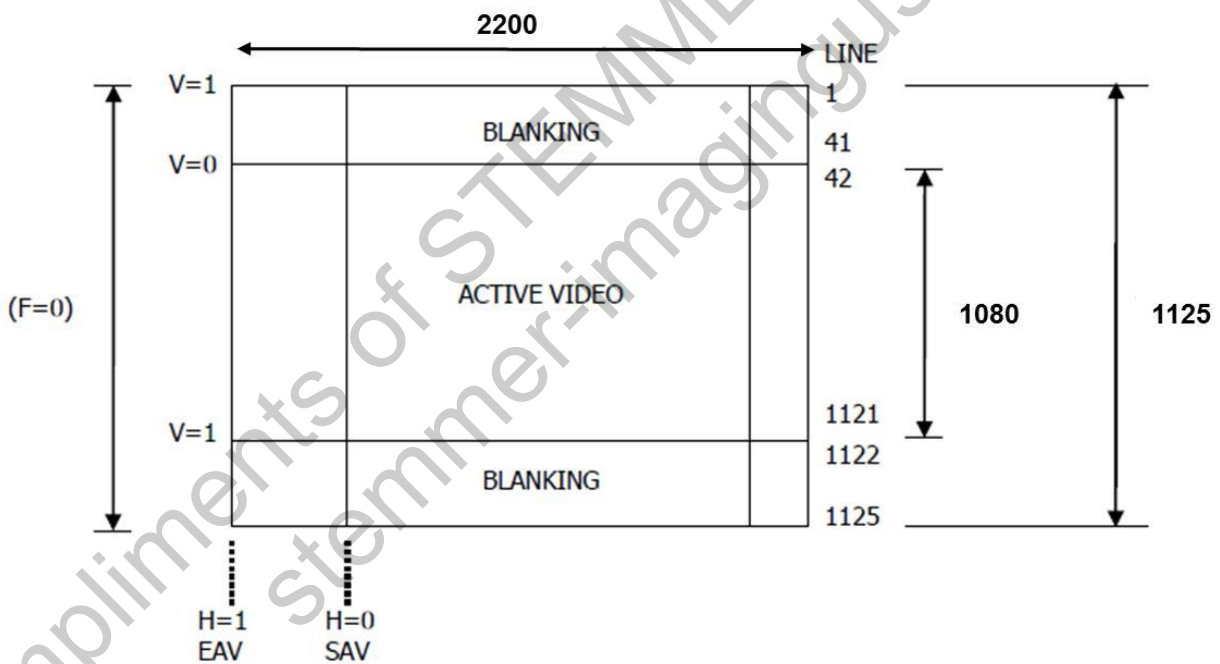



6.2. Output Timing Chart(1920x1080p@30/60/29.97/59.94)

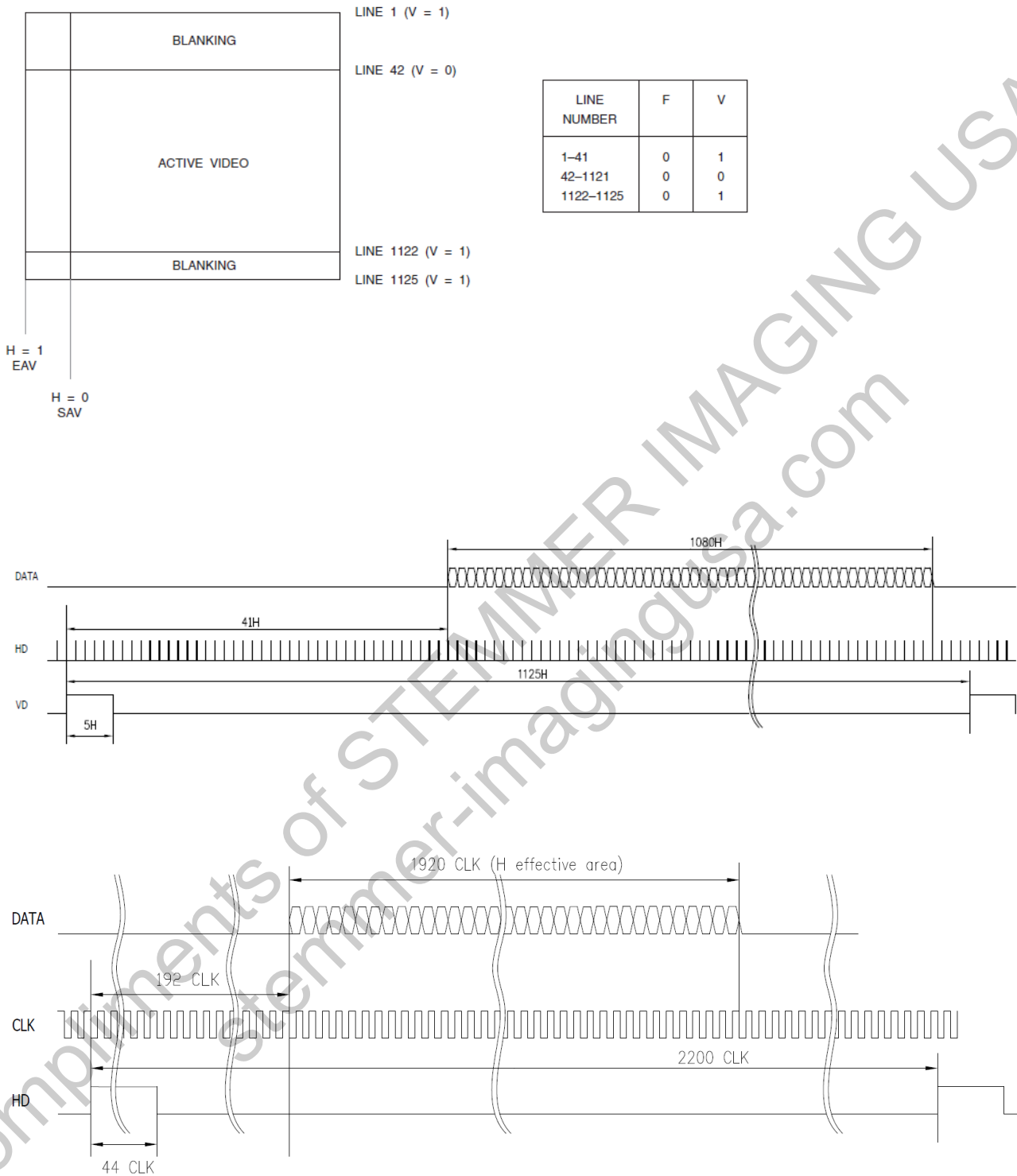



6.3. Output Timing Chart(1920x1080p@25/50)

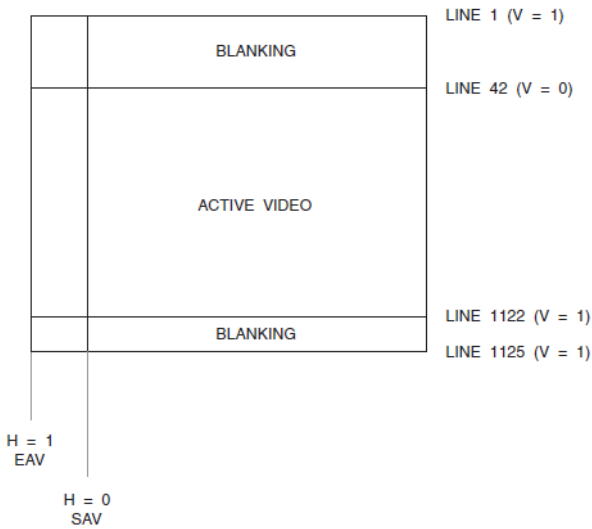

LINE NUMBER	F	V
1-41	0	1
42-1121	0	0
1122-1125	0	1

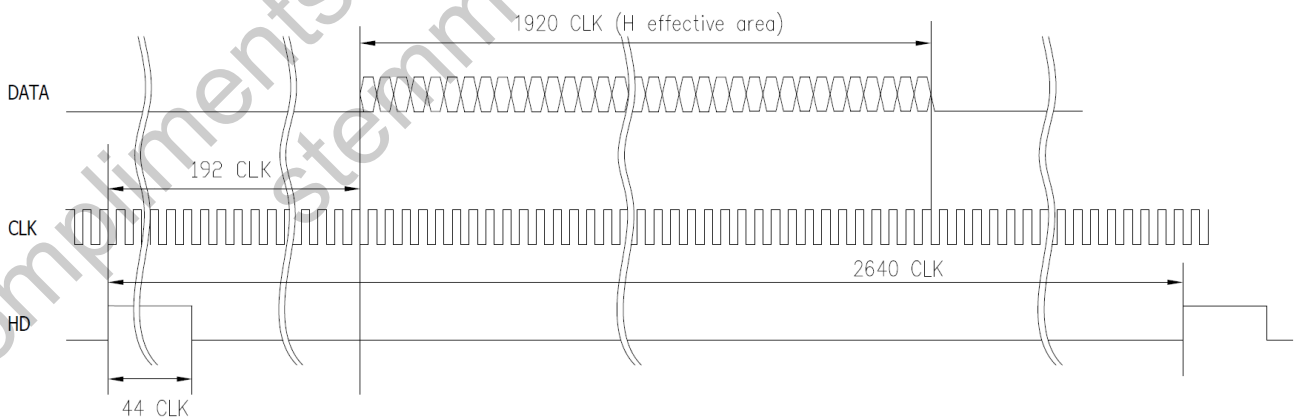
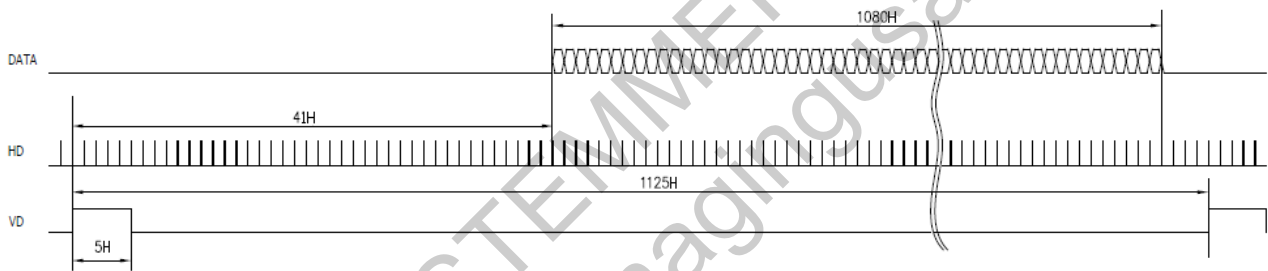



6.4. Output Timing Chart(1920x1080i@60/59.94)

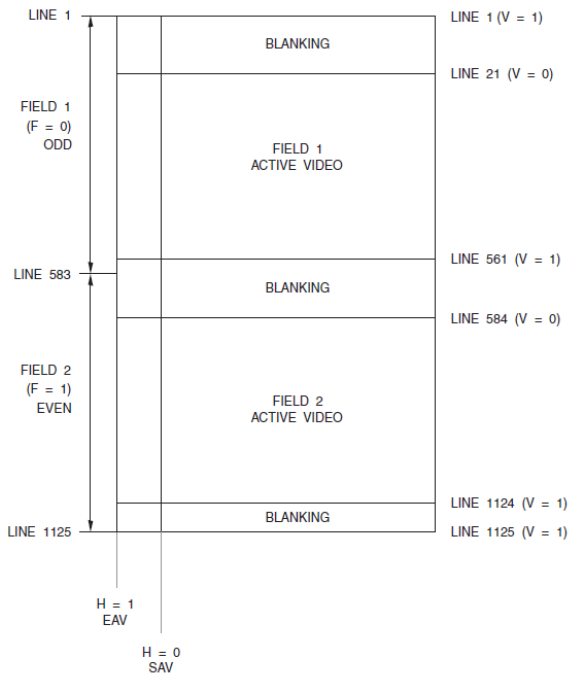

LINE NUMBER	F	V
1-20	0	1
21-560	0	0
561-562	0	1
563-583	1	1
584-1123	1	0
1124-1125	1	1

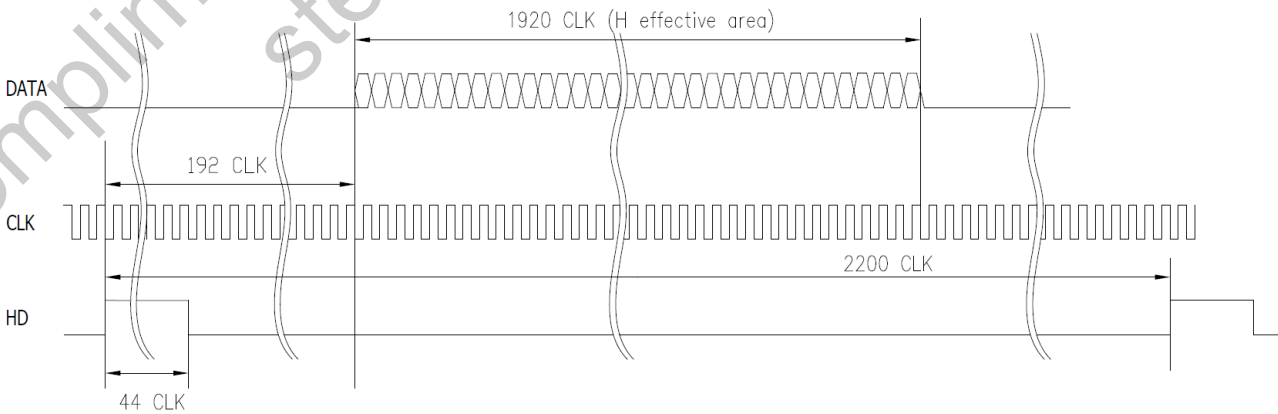
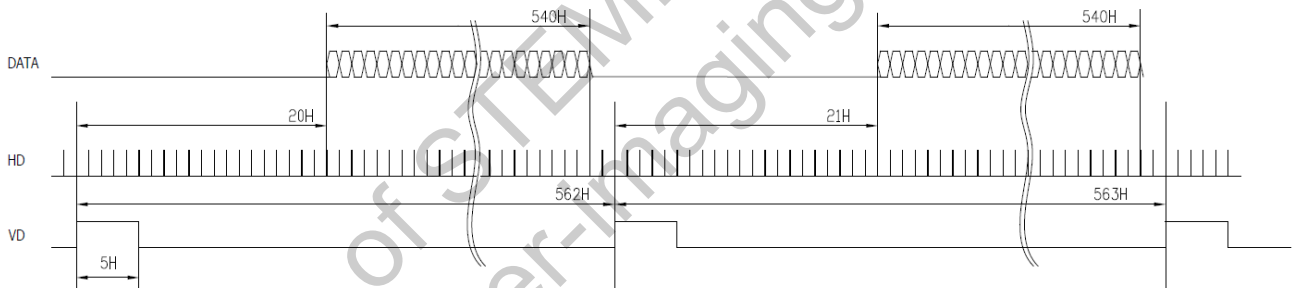



6.5. Output Timing Chart(1920x1080i@50)

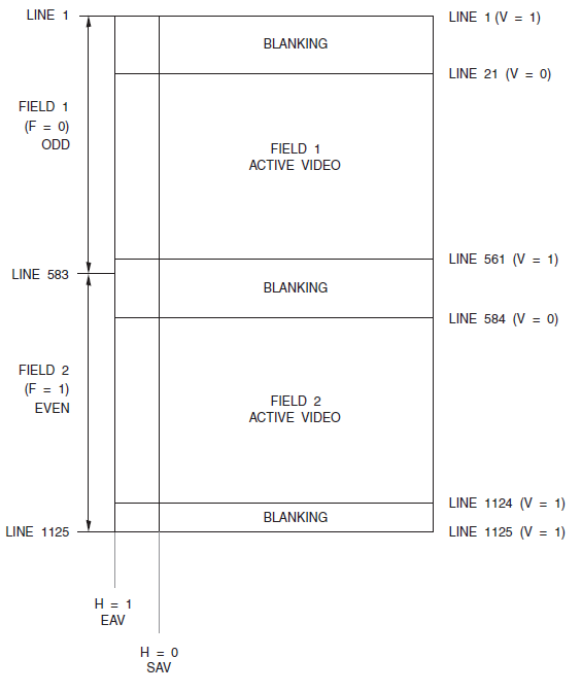

LINE NUMBER	F	V
1-20	0	1
21-560	0	0
561-562	0	1
563-583	1	1
584-1123	1	0
1124-1125	1	1

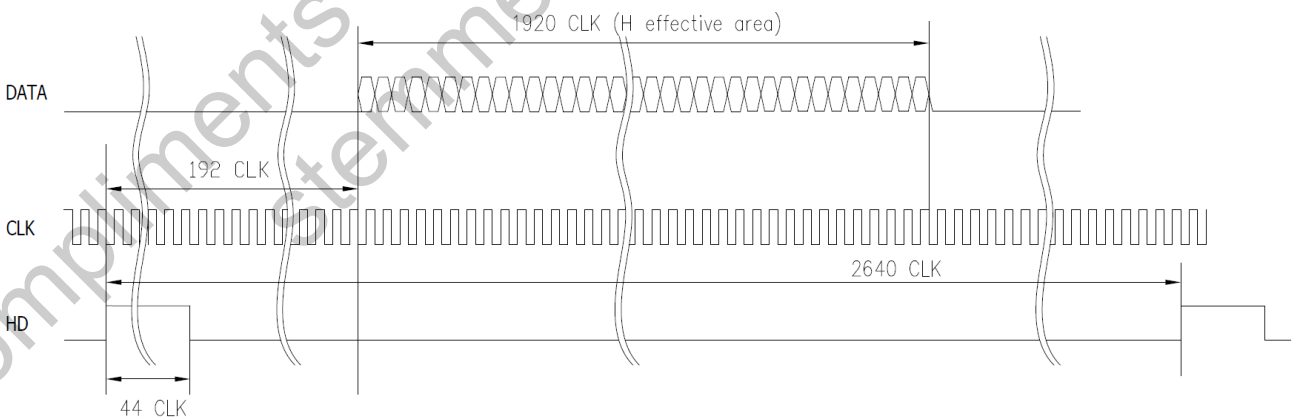
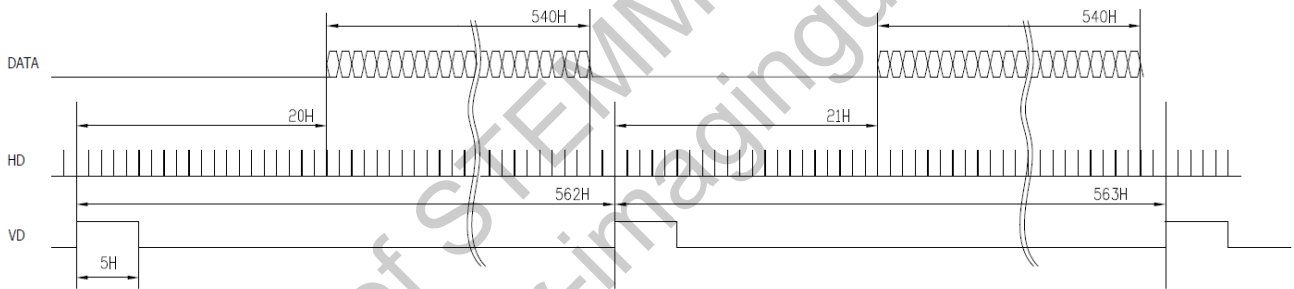



6.6. Output Timing Chart(1280x720p@60/59.94)

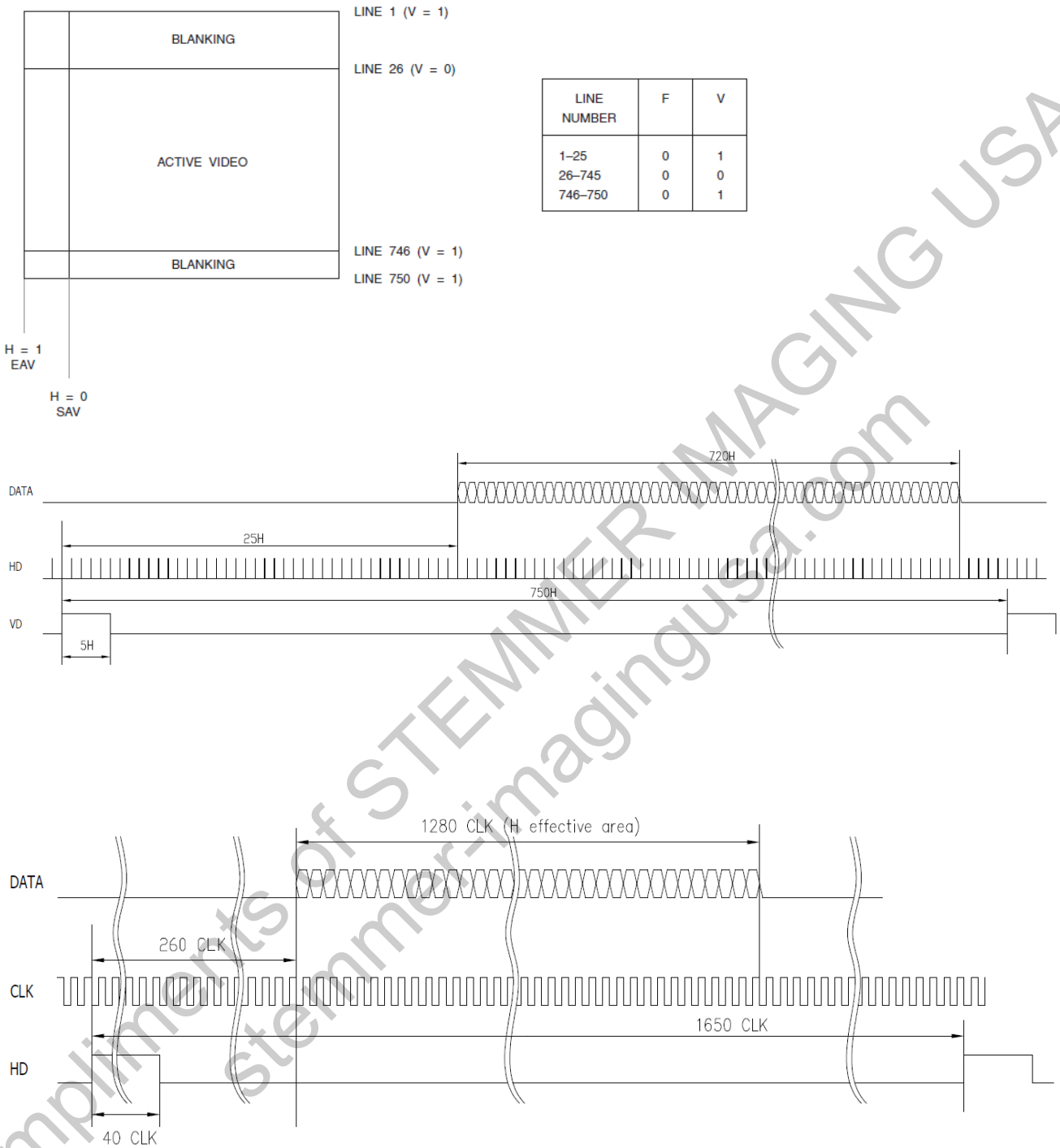



6.7. Output Timing Chart(1280x720p@50)

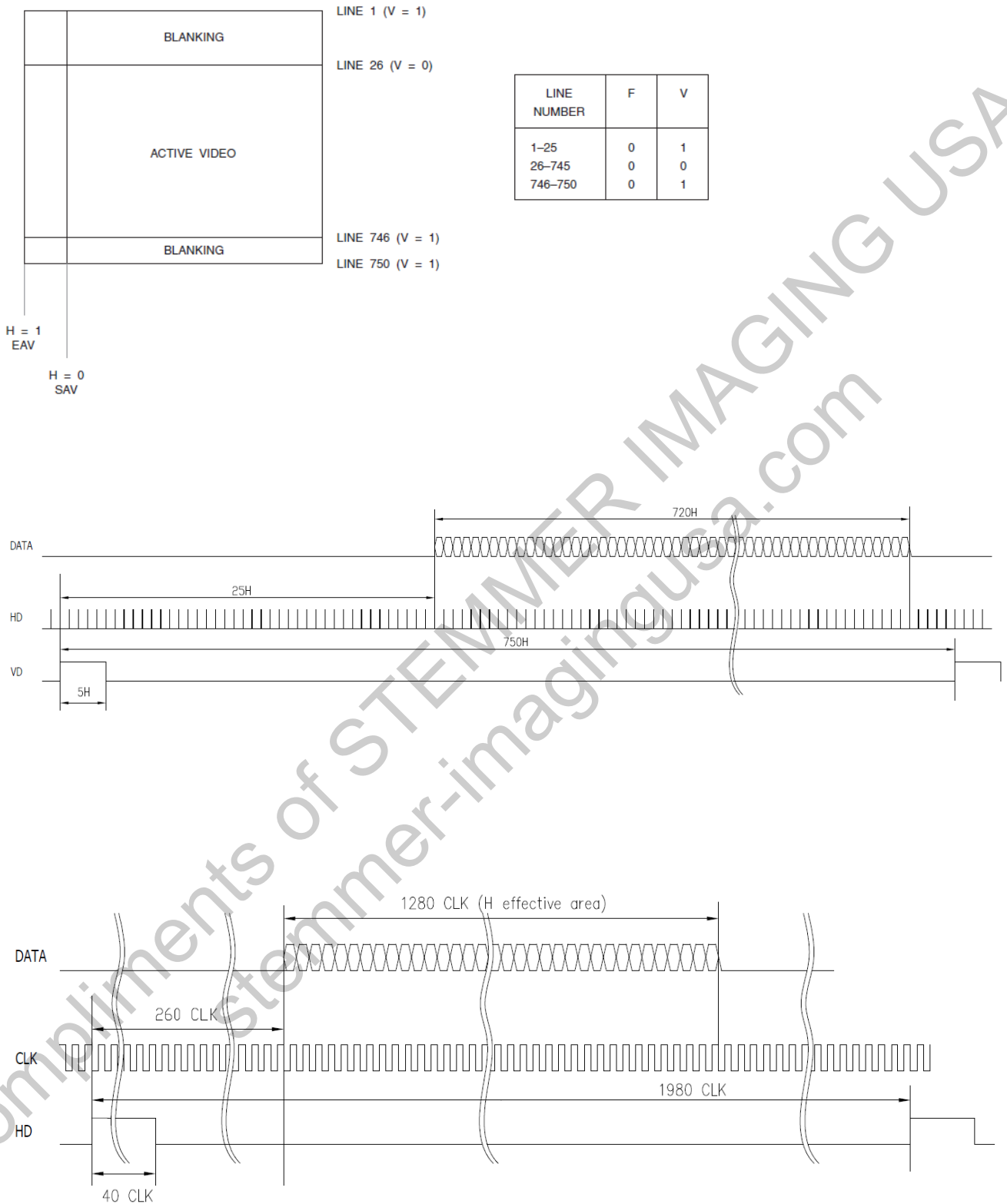



6.8. Output Timing Chart(1280x720p@30/29.97)

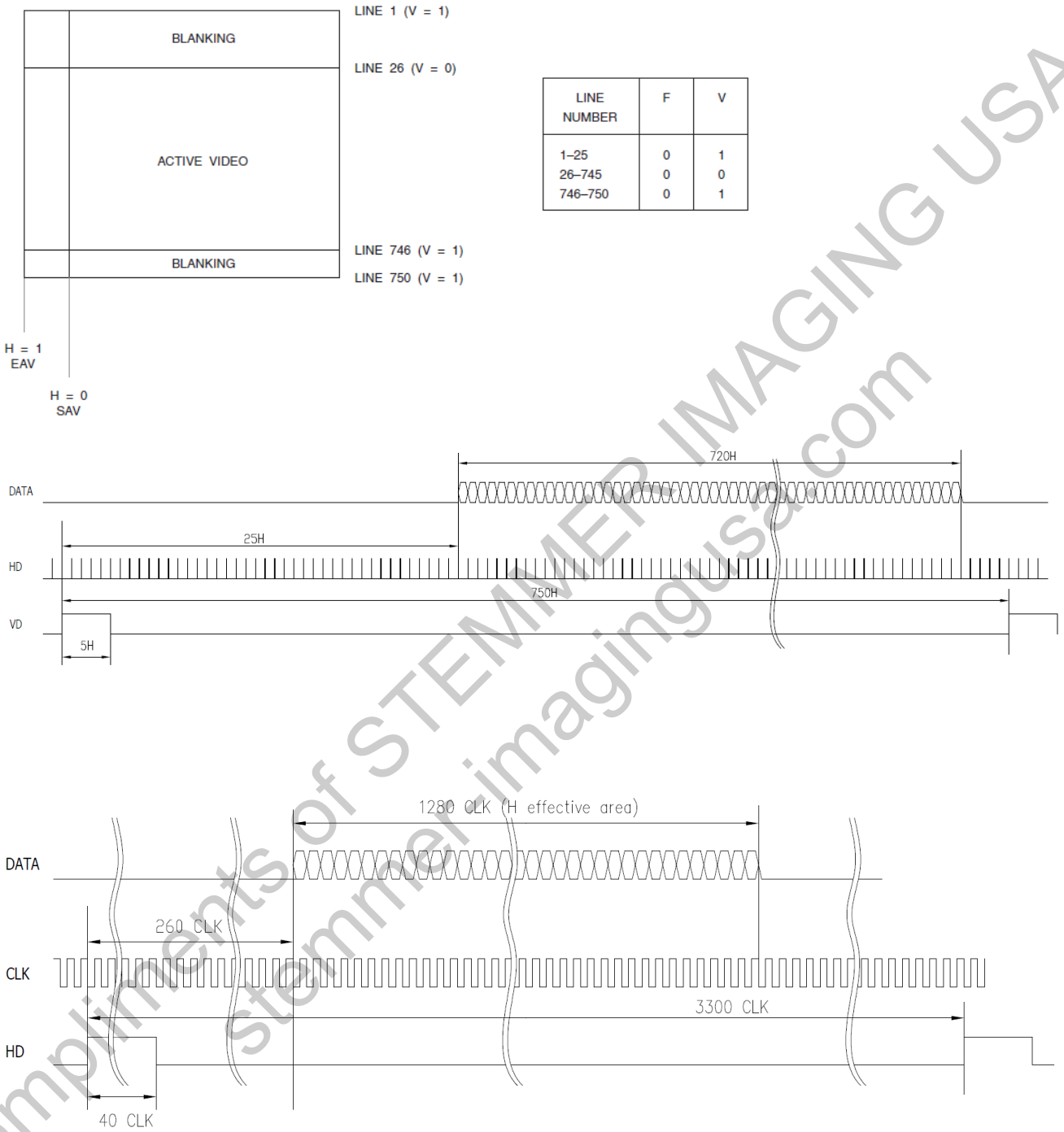



6.9. Output Timing Chart(1280x720p@25)

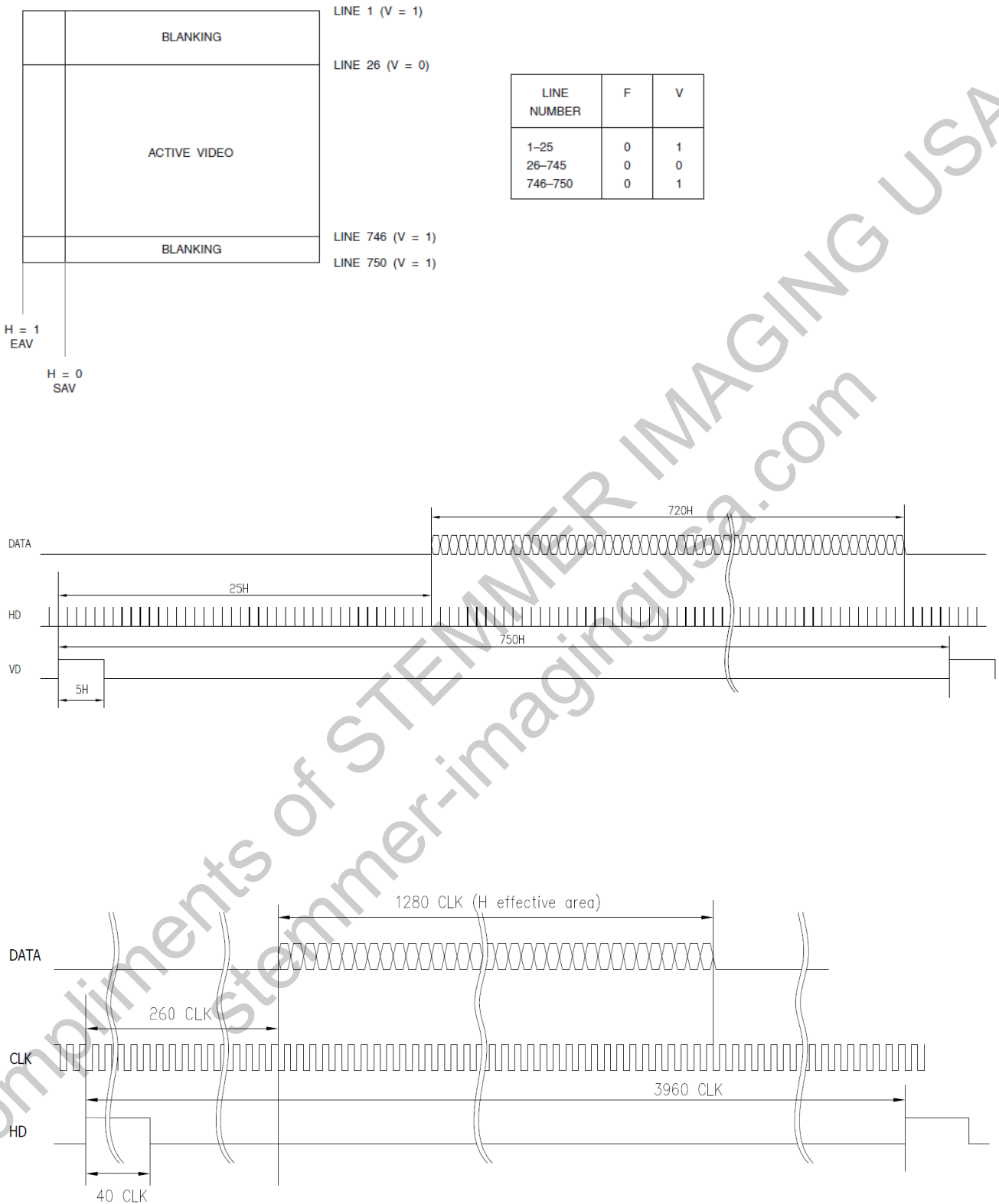



6.10. Video Data Start/Stop Format

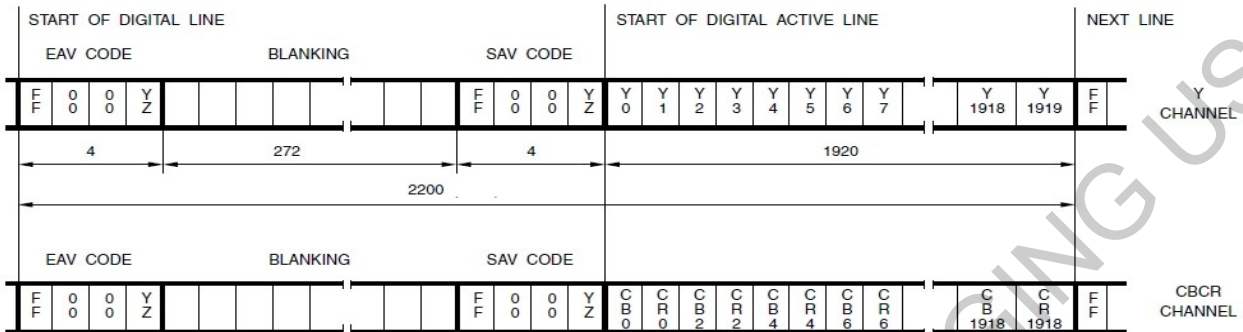

EAV and SAV CODE

	D7(MSB)	D6	D5	D4	D3	D2	D1	D0(LSB)
Preamble	1	1	1	1	1	1	1	1
	0	0	0	0	0	0	0	0
	0	0	0	0	0	0	0	0
Status word	1	F	V	H	P3	P2	P1	P0

EAV and SAV Sequence

The EAV and SAV sequences are shown in Table A. The status word is defined as:

F = "0" or "1" (Selectable)

V = "1" during vertical blanking

H = "0" at SAV H = "1" at EAV

P3-P0 = protection bits

$$P3 = V \oplus H$$

$$P2 = F \oplus H$$

$$P1 = F \oplus V$$

$$P0 = F \oplus V \oplus H$$



7. Camera Interface

7.1. Camera Interface

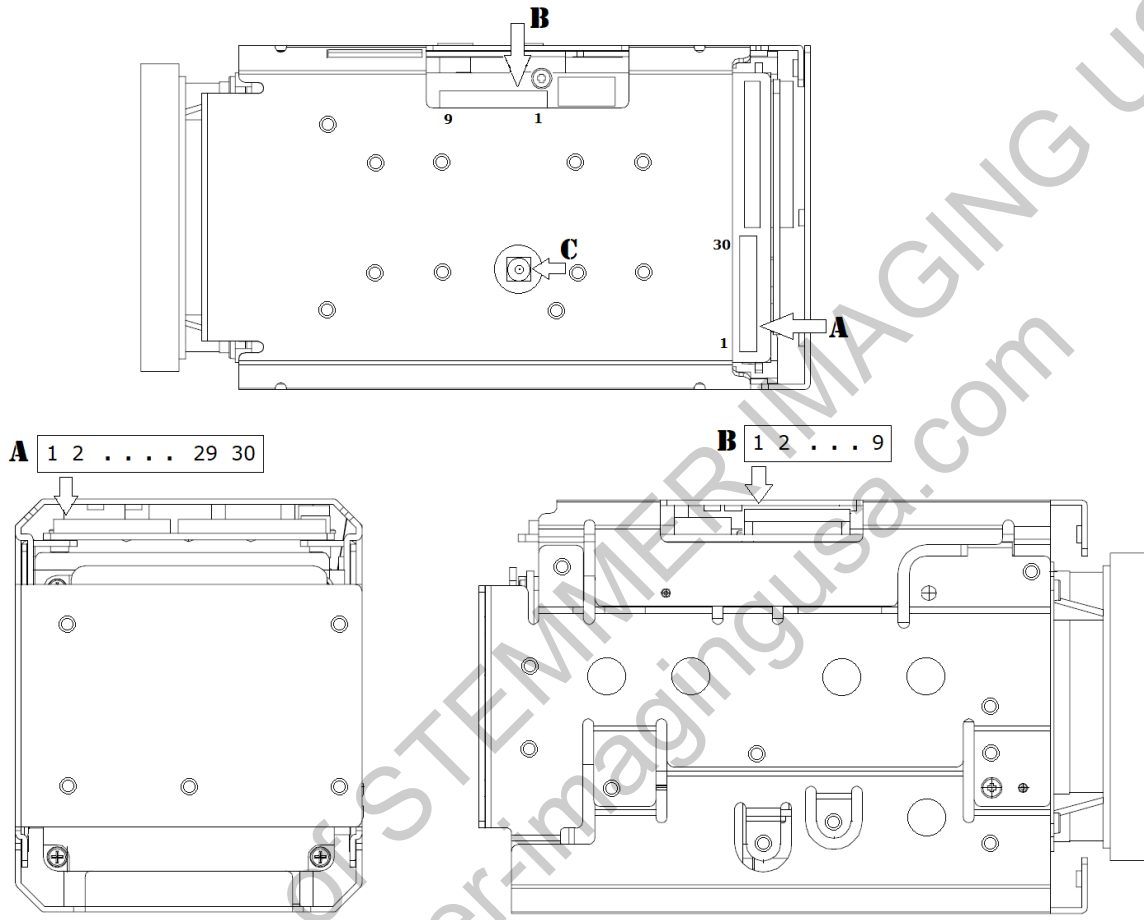

Compliments of STEMMER IMAGING USA
stemmer-imagingusa.com



B connector:

Connector – Molex 52271-0979 (1.0mm pitch, Bottom Contact)

Pin	Name	Level
1	RXD (UART input)	CMOS 5V (High Min. 2.5V)
2	TXD (UART output)	CMOS 5V (High Min. 4.5V)
3	GND	
4	DC power input	9 ~ 15VDC
5	GND	
6	CVBS Output	
7	GND	
8	N.C	
9	N.C	

C connector: SDI

Connector –MMCX (micro-miniature coaxial) Female Jack (product called 21Z30S - MMCX) or u-fl (ultra small coaxial connector) Female jack (product called 21Z30S- ufl)

A connector :Recommended cable ASSY :

Cables - micro coaxial cable #42AWG

Connectors - USL20-30S (KEL)

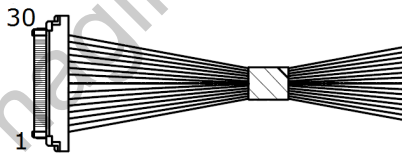

Camera Side

KEL USL00-30L			
1	TXOUT3+ (LVDS)	16	DC (9~15V)
2	TXOUT3- (LVDS)	17	DC (9~15V)
3	TXCLKOUT+ (LVDS)	18	DC (9~15V)
4	TXCLKOUT- (LVDS)	19	KEY input
5	TXOUT2+ (LVDS)	20	GND
6	TXOUT2- (LVDS)	21	TXOUT7+ (LVDS) for Dual out mode
7	TXOUT1+ (LVDS)	22	TXOUT7- (LVDS) for Dual out mode
8	TXOUT1- (LVDS)	23	TXOUT6+ (LVDS) for Dual out mode
9	TXOUT0+ (LVDS)	24	TXOUT6- (LVDS) for Dual out mode
10	TXOUT0- (LVDS)	25	CVBS output
11	GND	26	EXT. Reset :Reset Low(GND), Normal Open(3.3V)



12	TXD (UART output) High Min. 4.5V	27	TXOUT5+ (LVDS) for Dual out mode
13	RXD (UART input) High Min. 2.5V	28	TXOUT5- (LVDS) for Dual out mode
14	DC (9~15V)	29	TXOUT4+ (LVDS) for Dual out mode
15	DC (9~15V)	30	TXOUT4- (LVDS) for Dual out mode

7.2. LVDS Interface

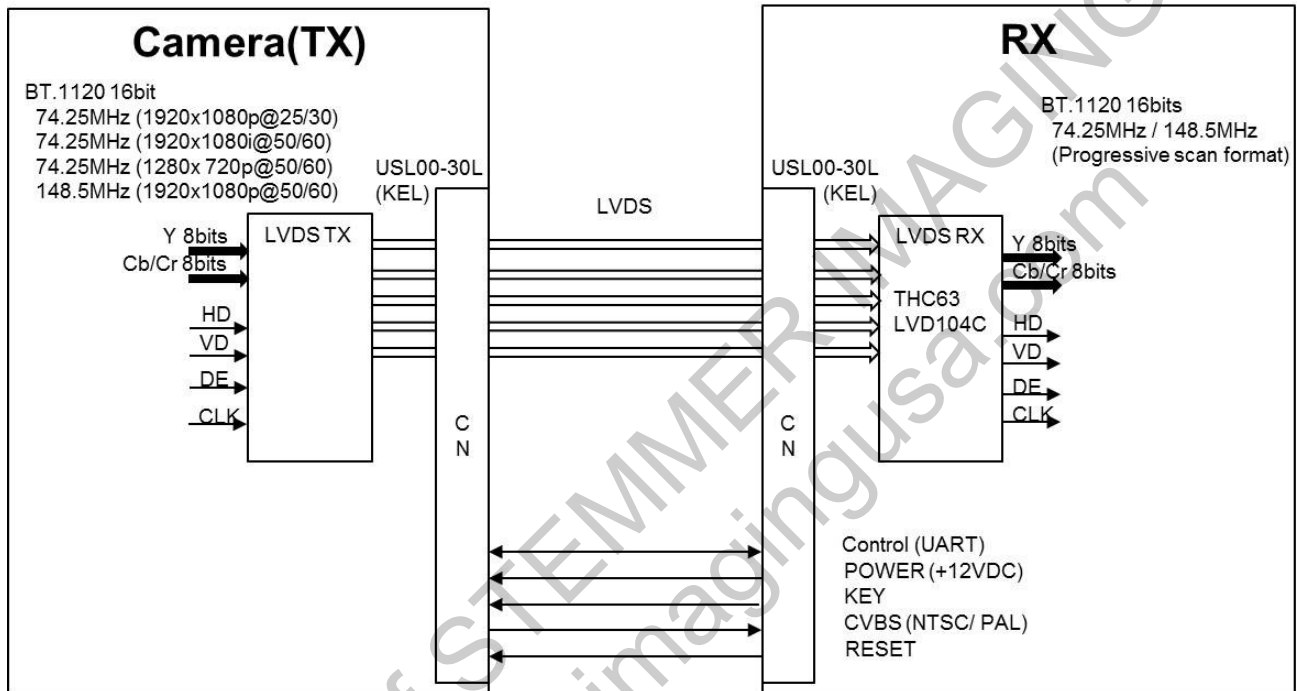

LVDS Single Output only

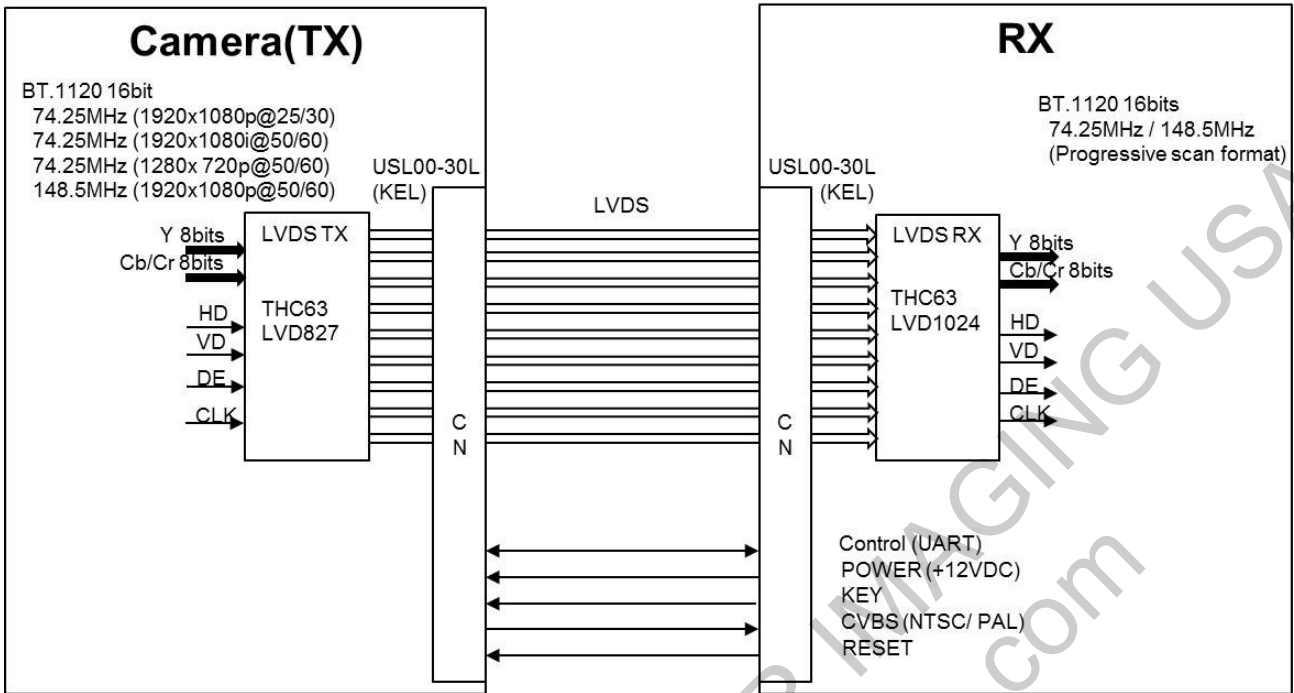

LVDS Single/Dual Output

LVDS Data Mapping

Single Mode (16bits)

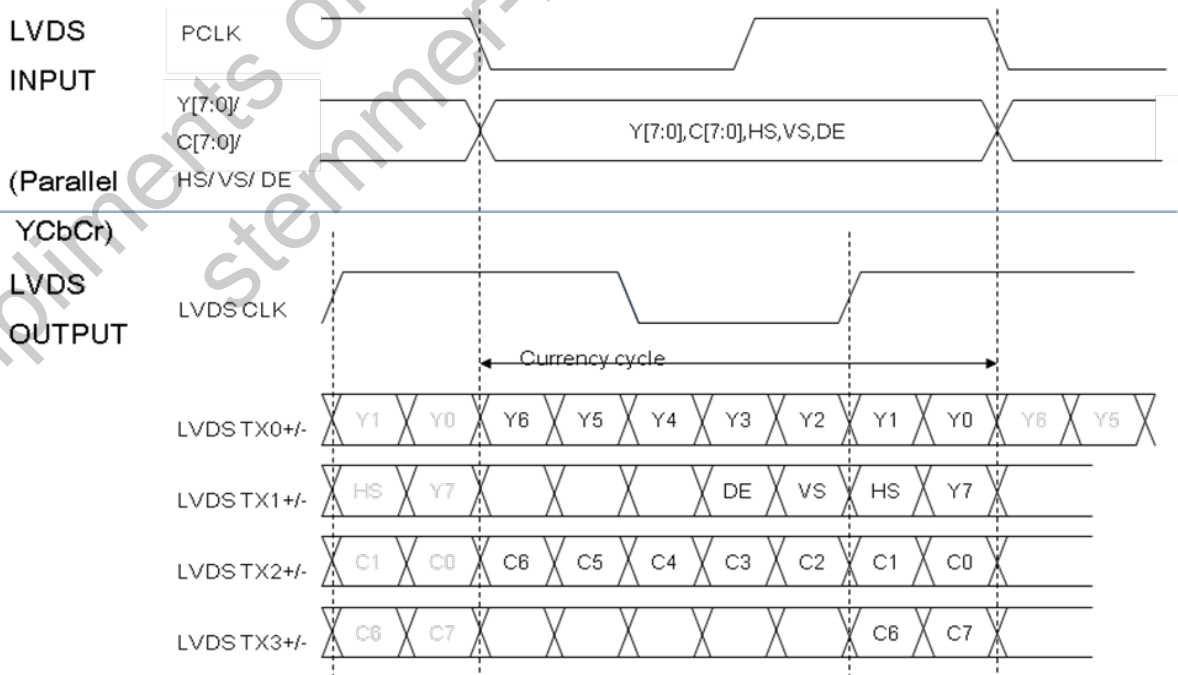



Dual Mode (16bits)

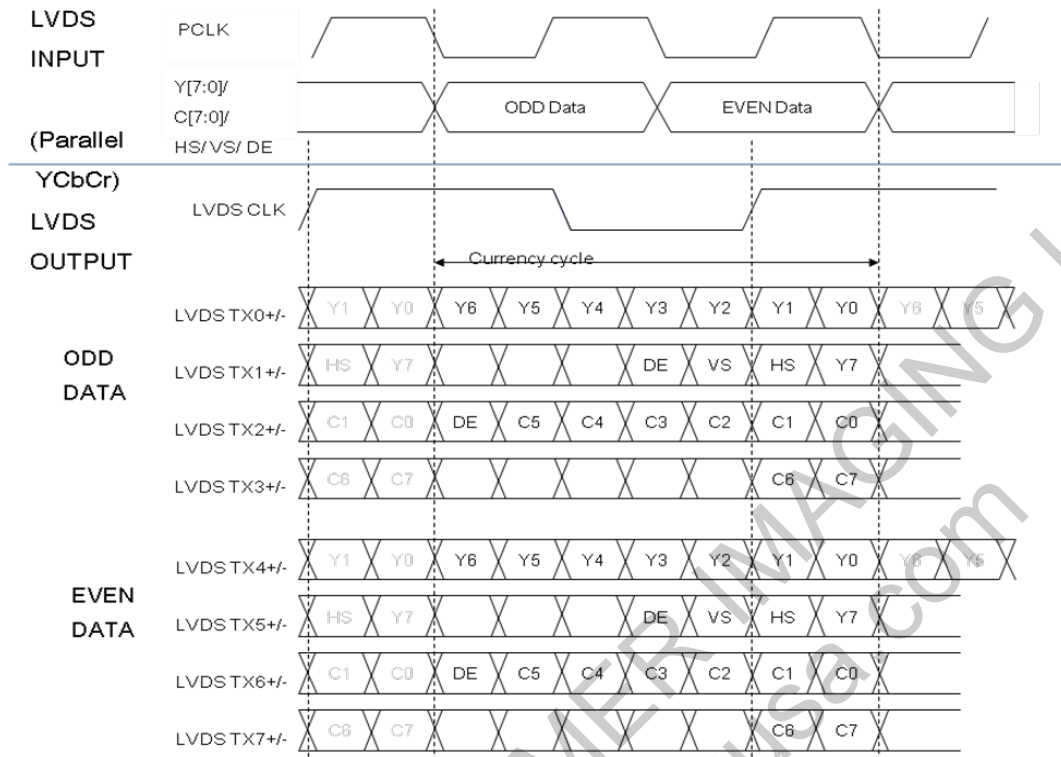

7.3. Application of recommended circuit Camera Reception

LVDS Rx(THC63LVD104C) circuit (Single Output Only)

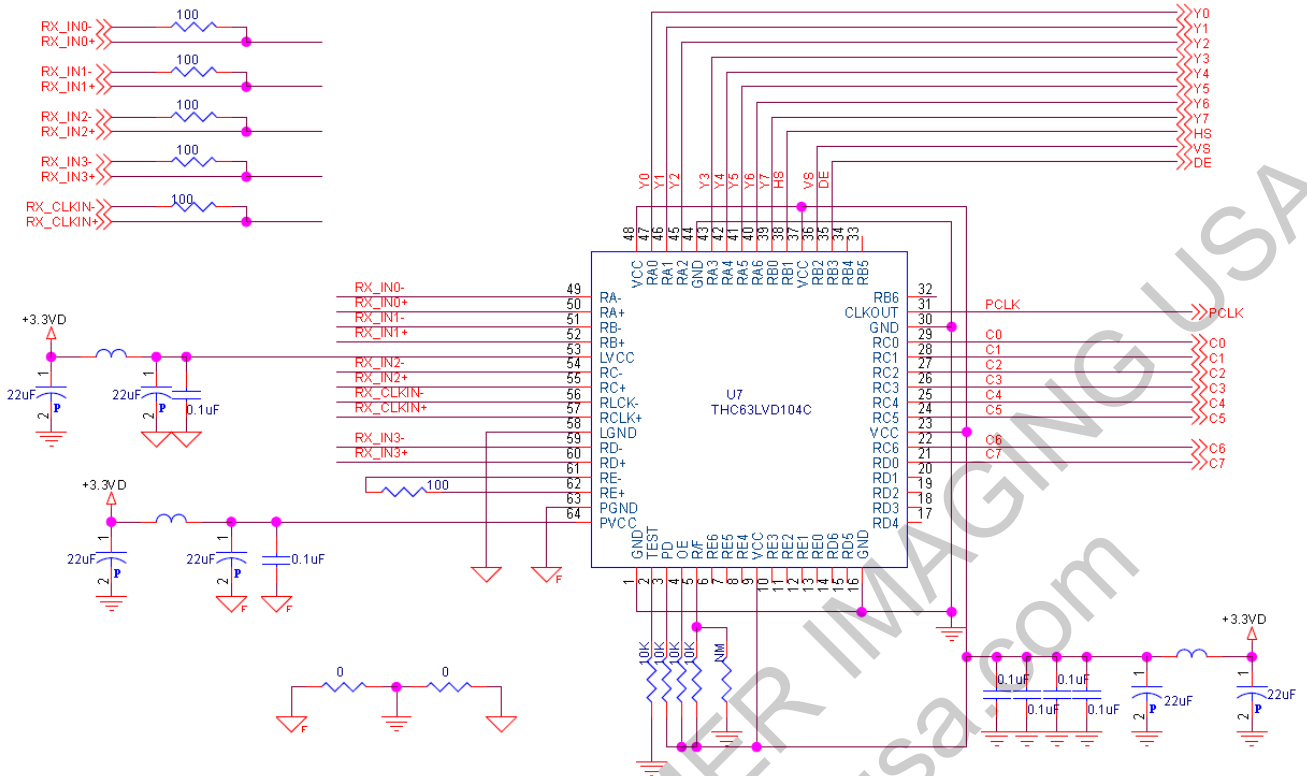

Compliments of STEMMER IMAGING USA
stemmer-imagingusa.com



LVDS Rx(THC63LVD1024) circuit (Single output)

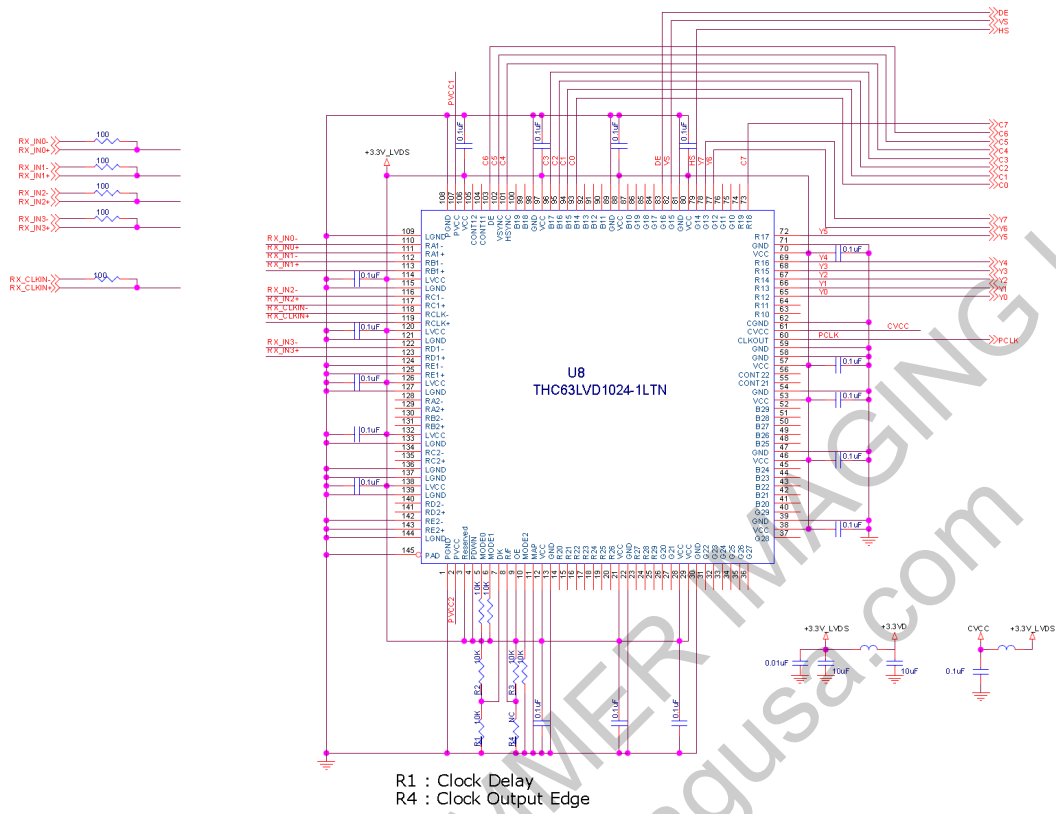

LVDS Rx(THC63LVD1024) circuit (Dual output)

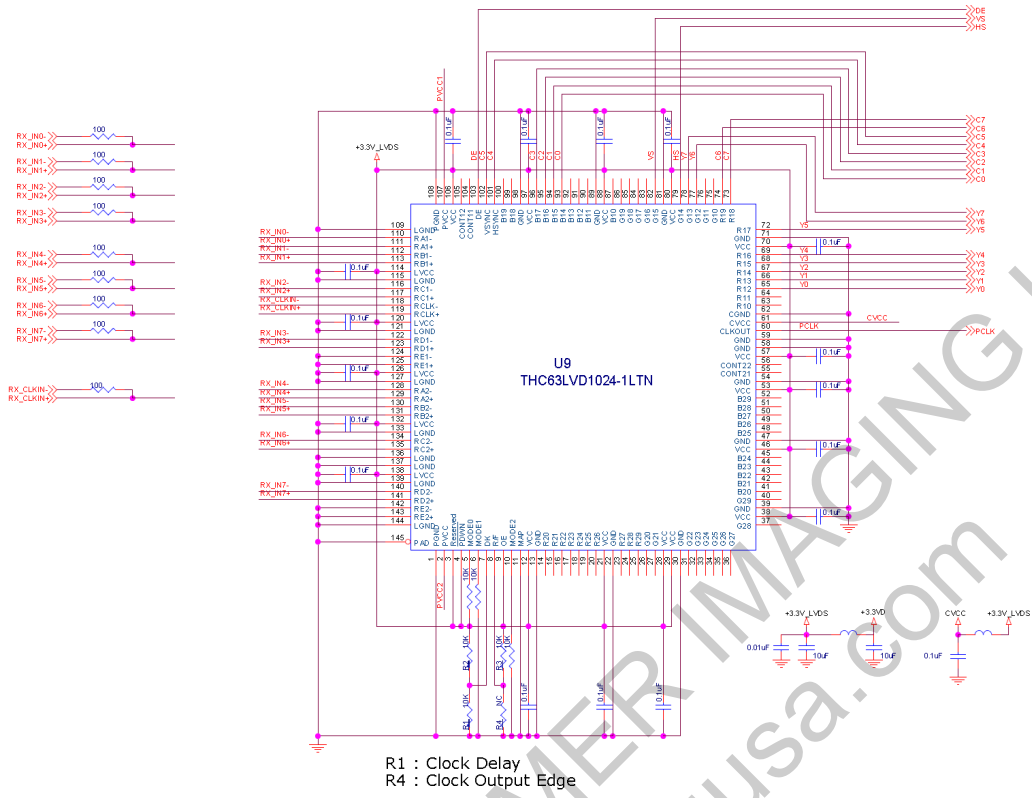

7.4. Key Application recommended circuit

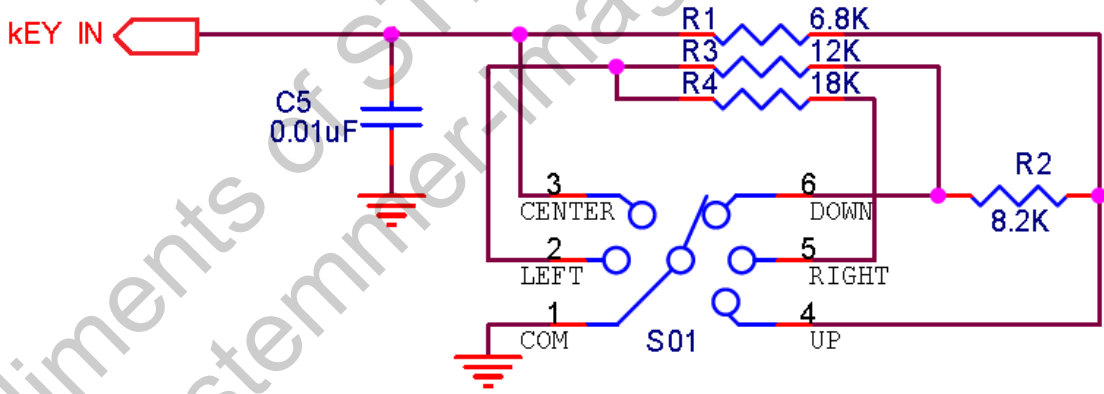



8. Dimensions

Front

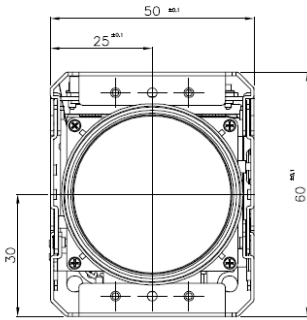

Right side

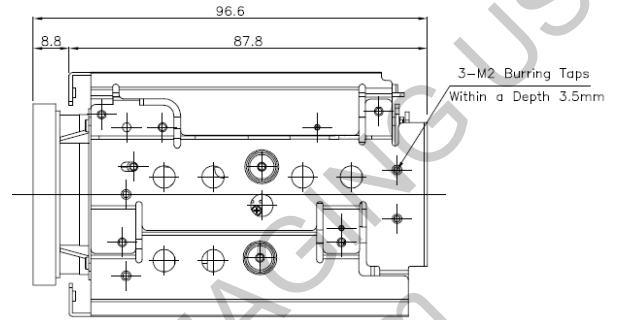

Top

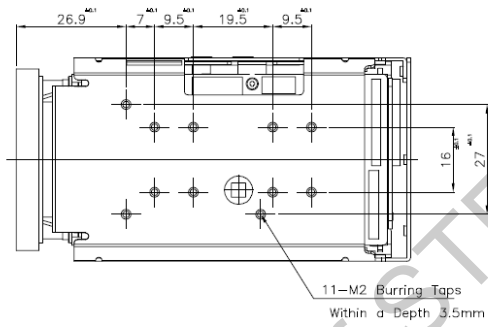

Left side

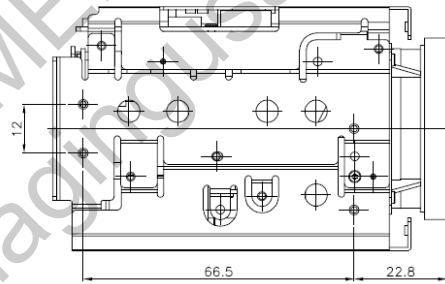

Bottom

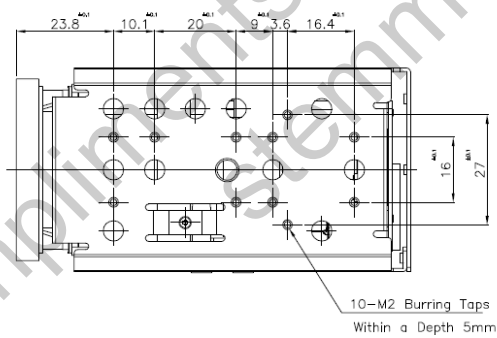

Back

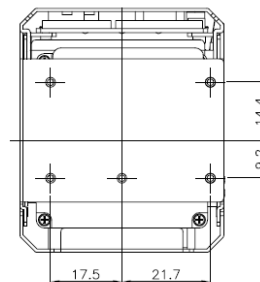



APPENDIX A

VISCA Protocol

9600, 19200, 38400, 115200bps 8bit data 1stop bit none parity

Command Packet (3~ 16bytes)			Comments
Inquiry		8X QQ RR ... FF	8X: 0x80+Sender addr(H nibble)+Recv addr(L nibble) addr(1~7) QQ: 01-Command/ 00-Inquiry RR: Category 00(Interface) 04(cam1) 06(Pan/Tilt) 07(cam2) FF: Terminator (0xff)
Reply Packet			
Completion message	ACK	X0 4Y FF	X = 9 to F: Camera address + 8
	Completion (commands)	X0 5Y FF	Y: socket number
	Completion (Inquiries)	X0 5Y ... FF	
Reply Packet			
Error message	Error	X0 6Y 01 FF	Message length error (>14 bytes)
		X0 6Y 02 FF	Syntax Error
		X0 6Y 03 FF	Command buffer full
		X0 6Y 04 FF	Command cancelled
		X0 6Y 05 FF	No socket (to be cancelled)
		X0 6Y 41 FF	Command not executable
X = 9 to F: Camera address + 8, Y = socket number			
Command execution cancel	cancel	8X 2Y FF	X = 1 to 7: Camera address, Y = socket number
Network Change Address	Network Change	88 30 01 FF .	Always broadcasted
		X0 38 FF	X = 9 to F: Camera address + 8



	Command Packet	Reply Packet
IF_Clear	8X 01 00 01FF	X0 50 FF
IF_Clear (broad-cast)	88 01 00 01 FF	88 01 00 01 FF

	Inquiry Packet	Reply Packet	
CAM_VersionInq	8X 09 00 02 FF	Y0 50 GG GG HH HH JJ JJ KK FF	GGGG = Vender ID 002B: HHHH = Model ID 1020: IVZ-FU10 x10 FullHD module 2021: IVZ-FU20 x20 FullHD module 3020: IVZ-FZ30 x30 FullHD module 3520: IVZ-FZ36 x36 FullHD module JJJJ = ROM revision KK = Maximum socket #(02)

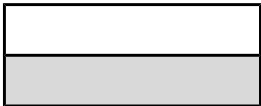

Implemented Command

not Implemented Command

Compliments of STEMMER IMAGING USA
stemmer-imagingusa.com



Command Set

Command Set	Command	Packet	Comments
AddressSet	Broadcast	88 30 01 FF	Address setting
IF_Clear	Broadcast	88 01 00 01 FF	I/F Clear
CommandCancel		8x 2p FF	p: Socket No. (=1 or 2)
CAM_Power	On	8x 01 04 00 02 FF	Power ON/OFF (specific model *m1)
	Off(Standby)	8x 01 04 00 03 FF	
CAM_Zoom	Stop	8x 01 04 07 00 FF	
	Tele (Standard)	8x 01 04 07 02 FF	
	Wide (Standard)	8x 01 04 07 03 FF	
	Tele (Variable)	8x 01 04 07 2p FF	p=0 (Low) to 7 (High)
	Wide (Variable)	8x 01 04 07 3p FF	
	Direct (AF Zoom)	8x 01 04 47 0p 0q 0r 0s FF	pqrs: Zoom Position (refer Table) Auto Focusing during Zooming
	Direct (Non AF Zoom)	8x 01 04 45 0p 0q 0r 0s FF	pqrs: Zoom Position (refer Table) Non AF during Zooming
	Direct (AF Zoom) variable	8x 01 04 47 0n 0p 0q 0r 0s FF	n: zoom speed 0(low) to 7(high) pqrs: Zoom Position (refer Table) Auto Focusing during Zooming
CAM_DZoom	On	8x 01 04 06 02 FF	Digital zoom ON/OFF
	Off	8x 01 04 06 03 FF	
	Combine Mode	8x 01 04 36 00 FF	Optical/Digital Zoom Combined
	Separate Mode	8x 01 04 36 01 FF	Optical/Digital Zoom Separate
	Stop	8x 01 04 06 00 FF	
	Tele (Variable)	8x 01 04 06 2p FF	p=0 (Low) to 7 (High)
	Wide (Variable)	8x 01 04 06 3p FF	* Enabled during Separate Mode
	x1/Max	8x 01 04 06 10 FF	x1/MAX Magnification Switchover * Enabled during Separate Mode
Direct	8x 01 04 46 0p 0q 0r 0s FF	pq: D-Zoom Position * Enabled during Separate Mode	



Command Set

Command Set	Command	Packet	Comments
CAM_Focus	Stop	8x 01 04 08 00 FF	
	Far (Standard)	8x 01 04 08 02 FF	
	Near (Standard)	8x 01 04 08 03 FF	
	Far (Variable)	8x 01 04 08 2p FF	p=0 (Low) to 7 (High)
	Near (Variable)	8x 01 04 08 3p FF	
	Direct	8x 01 04 48 0p 0q 0r 0s FF	pqrs: Focus Position (0x1000 - 0xC000)
	Auto Focus	8x 01 04 38 02 FF	AF ON/OFF
	Manual Focus	8x 01 04 38 03 FF	
	Auto/Manual	8x 01 04 38 10 FF	
	One Push Trigger	8x 01 04 18 01 FF	One Push AF Trigger
	<i>Infinity</i>	<i>8x 01 04 18 02 FF</i>	<i>Forced infinity</i>
Near Limit	8x 01 04 28 0p 0q 0r 0s FF	pqrs: Focus Near Limit Position	
AF Sensitivity	Normal	8x 01 04 58 02 FF	AF Sensitivity High/Low
	Low	8x 01 04 58 03 FF	
CAM_AFMode	Normal AF	8x 01 04 57 00 FF	AF Movement Mode
	Interval AF	8x 01 04 57 01 FF	
	Zoom Trigger AF	8x 01 04 57 02 FF	
	Active/Interval Time	8x 01 04 27 0p 0q 0r 0s FF	pq: Movement Time, rs: Interval
CAM_IRCorrection	Standard	8x 01 04 11 00 FF	FOCUS IR compensation data switching
	IR Light	8x 01 04 11 01 FF	
CAM_ZoomFocus	Direct	8x 01 04 47 0p 0q 0r 0s 0t 0u	pqrs: Zoom Position (refer Table)
		0v 0w FF	tuvw: Focus Position
CAM_ZoomFocus variable	Direct	8x 01 04 47 0n 0p 0q 0r 0s 0t	n: zoom speed 0(low) to 7(high)
		0u 0v 0w FF	pqrs: Zoom Position (refer Table) tuvw: Focus Position
CAM_Initialize	Lens	8x 01 04 19 01 FF	Lens Initialization Start
	Camera	8x 01 04 19 03 FF	Camera reset



Command Set

Command Set	Command	Packet	Comments
CAM_WB	Auto	8x 01 04 35 00 FF	Normal Auto
	Indoor	8x 01 04 35 01 FF	Indoor mode
	Outdoor	8x 01 04 35 02 FF	Outdoor mode
	One Push WB	8x 01 04 35 03 FF	One Push WB mode
	ATW	8x 01 04 35 04 FF	Auto Tracing White Balance
	Manual	8x 01 04 35 05 FF	Manual Control mode
	One Push Trigger	8x 01 04 10 05 FF	One Push WB Trigger
	<i>Outdoor Auto</i>	<i>8x 01 04 35 06 FF</i>	<i>Outdoor auto</i>
	<i>Sodium Lamp Auto</i>	<i>8x 01 04 35 07 FF</i>	<i>Auto including sodium lamp source</i>
<i>Sodium Lamp</i>	<i>8x 01 04 35 08 FF</i>	<i>Sodium lamp source fixed mode</i>	
CAM_RGain	Reset	8x 01 04 03 00 FF	Manual Control of R Gain
	Up	8x 01 04 03 02 FF	
	Down	8x 01 04 03 03 FF	
	Direct	8x 01 04 43 00 00 0p 0q FF	pq: R Gain (0 to 0xFF)
CAM_BGain	Reset	8x 01 04 04 00 FF	Manual Control of B Gain
	Up	8x 01 04 04 02 FF	
	Down	8x 01 04 04 03 FF	
	Direct	8x 01 04 44 00 00 0p 0q FF	pq: B Gain (0 to 0xFF)
CAM_AE	Full Auto	8x 01 04 39 00 FF	Automatic Exposure mode
	Manual	8x 01 04 39 03 FF	Manual Control mode
	Shutter Priority	8x 01 04 39 0A FF	Shutter Priority Automatic Exposure mode
	Iris Priority	8x 01 04 39 0B FF	Iris Priority Automatic Exposure mode
	Bright	8x 01 04 39 0D FF	Bright Mode (Manual control)
CAM_SlowShutter	Auto	8x 01 04 5A 02 FF	Auto Slow Shutter ON/OFF
	Manual	8x 01 04 5A 03 FF	
CAM_Shutter	Reset	8x 01 04 0A 00 FF	Shutter Setting
	Up	8x 01 04 0A 02 FF	
	Down	8x 01 04 0A 03 FF	
	Direct	8x 01 04 4A 00 00 0p 0q FF	pq: Shutter Position (refer Table)
CAM_Iris	Reset	8x 01 04 0B 00 FF	Iris Setting
	Up	8x 01 04 0B 02 FF	
	Down	8x 01 04 0B 03 FF	
	Direct	8x 01 04 4B 00 00 0p 0q FF	pq: Iris Position (0 to 0x11) (refer Table)



Command Set

Command Set	Command	Packet	Comments
CAM_Gain	Reset	8x 01 04 0C 00 FF	Gain Setting
	Up	8x 01 04 0C 02 FF	
	Down	8x 01 04 0C 03 FF	
	Direct	8x 01 04 4C 00 00 0p 0q FF	pq: Gain Position (0 to 0x0F) (refer Table)
	Gain Limit	8x 01 04 2C 0p FF	p: Gain Position (refer Table)
CAM_Bright	Reset	8x 01 04 0D 00 FF	Bright Setting
	Up	8x 01 04 0D 02 FF	
	Down	8x 01 04 0D 03 FF	
	Direct	8x 01 04 4D 00 00 0p 0q FF	pq: Bright Position (0 to 0x1f) (refer Table)
CAM_ExpComp	On	8x 01 04 3E 02 FF	Exposure Compensation ON/OFF
	Off	8x 01 04 3E 03 FF	
	Reset	8x 01 04 0E 00 FF	Exposure Compensation Amount Setting
	Up	8x 01 04 0E 02 FF	
	Down	8x 01 04 0E 03 FF	
	Direct	8x 01 04 4E 00 00 0p 0q FF	pq: ExpComp Position (0 to 0x0E)
CAM_BackLight	On	8x 01 04 33 02 FF	Back Light Compensation ON/OFF
	Off	8x 01 04 33 03 FF	
CAM_SpotAE	On	8x 01 04 59 02 FF	Spot Automatic Exposure Setting
	Off	8x 01 04 59 03 FF	
	Position	8x 01 04 29 0p 0q 0r 0s FF	pq: X (0 to F), rs: Y (0 to F)
CAM_AEResponse	<i>Direct</i>	<i>8x 01 04 5D pp FF</i>	<i>pp: Automatic Exposure Response Setting (01 to 30)</i>
CAM_WD	On	8x 01 04 3D 02 FF	Wide-D ON/OFF
	Off	8x 01 04 3D 03 FF	
	VE On	8x 01 04 3d 06 FF	VE On
	Set Parameter	8x 01 04 2D 00 0q 0r 0s 00 00 00 00 FF	q: Display brightness level(0:Dark to 6:Bright) r: Brightness compensation selection (0: Very dark 1: Dark 2: Standard 3: Bright) s: Compensation level (0: L 1: M 2: H)
CAM_Aperture	Reset	8x 01 04 02 00 FF	Aperture Control
	Up	8x 01 04 02 02 FF	
	Down	8x 01 04 02 03 FF	
	Direct	8x 01 04 42 00 00 0p 0q FF	pq: Aperture Gain (0 to 0x14) (refer Table)



Command Set

Command Set	Command	Packet	Comments	
CAM_HR	On	8x 01 04 52 02 FF	High-Resolution Mode ON/OFF	
	Off	8x 01 04 52 03 FF		
CAM_NR		8x 01 04 53 0p FF	p: NR Setting (0:OFF 1:Low 2:Mid 3:High 4:Auto)	
CAM_Gamma		8x 01 04 5B 0p FF	p: Gamma setting (0~9) 0: Standard 1: Straight	
	Offset	8x 01 04 1E 00 00 00 0s 0t 0u FF	s: Polarity offset (0 is plus, 1 is minus) tu: Offset s=0 (00h to 40h) Offset s=1 (00h to 40h)	
CAM_HighSensitivity	On	8x 01 04 5E 02 FF	High Sensitivity mode ON/OFF	
	Off	8x 01 04 5E 03 FF		
CAM_LR_Reverse	On	8x 01 04 61 02 FF	Mirror Image ON/OFF	
	Off	8x 01 04 61 03 FF		
CAM_Freeze	On	8x 01 04 62 02 FF	Still Image ON/OFF	
	Off	8x 01 04 62 03 FF		
CAM_PictureEffect	Off	8x 01 04 63 00 FF	Picture Effect Setting	
	Neg.Art	8x 01 04 63 02 FF		
	B&W	8x 01 04 63 04 FF		
CAM_Defog	On	8x 01 04 37 02 0p FF	p:Defog level (0:auto, 1:low, 2:mid, 3:high)	
	Off	8x 01 04 37 03 00 FF		
CAM_PictureFlip	On	8x 01 04 66 02 FF	Picture flip ON/OFF	
	Off	8x 01 04 66 03 FF		
CAM_MinShutter	On	8x 01 04 12 02 FF		
	Off	8x 01 04 12 03 FF		
	Limit	8x 01 04 13 00 00 0p 0q FF		pq: Minimum Shutter Position (05h to 15h)
CAM_ICR	On	8x 01 04 01 02 FF	Infrared Mode ON/OFF	
	Off	8x 01 04 01 03 FF		
CAM_AutoICR	On	8x 01 04 51 02 FF	Auto dark-field mode On/Off	
	Off	8x 01 04 51 03 FF		
	Threshold	8x 01 04 21 00 00 0p 0q FF		pq: ICR On/Off Threshold Level(0 to 0x14)
CAM_AutoICR AlarmReply	On	8x 01 04 31 02 FF	Auto ICR switching Alarm ON/OFF	
	Off	8x 01 04 31 03 FF		
	(Reply)	y0 07 04 31 02 FF		ICR OFF -> ON
	(Reply)	y0 07 04 31 03 FF		ICR ON -> OFF



Command Set

Command Set	Command	Packet	Comments																																																																																																																																				
CAM_Stabilizer	On	8x 01 04 34 02 FF	Stabilizer ON/OFF/HOLD																																																																																																																																				
	Off	8x 01 04 34 03 FF																																																																																																																																					
	Hold	8x 01 04 34 00 FF																																																																																																																																					
CAM_Memory (Preset pos)	Reset	8x 01 04 3F 00 0p FF	p: Memory Number (=0 to 6)																																																																																																																																				
	Set	8x 01 04 3F 01 0p FF																																																																																																																																					
	Recall	8x 01 04 3F 02 0p FF																																																																																																																																					
CAM_CUSTOM	Reset	8x 01 04 3F 00 7F FF	Starts up in this mode when the power is turned on.																																																																																																																																				
	Set	8x 01 04 3F 01 7F FF																																																																																																																																					
	Recall	8x 01 04 3F 02 7F FF																																																																																																																																					
CAM_MemSave	Write	8x 01 04 23 0X 0p 0q 0r 0s FF	X: 00 to 07 (Address), total 16 byte pqrs: 0x0000 to 0xFFFF (Data)																																																																																																																																				
CAM_Display	On	8x 01 04 15 02 FF	Display ON/OFF																																																																																																																																				
	Off	8x 01 04 15 03 FF																																																																																																																																					
	On/Off	8x 01 04 15 10 FF																																																																																																																																					
CAM_MultiLineTitle	Title Set1	8x 01 04 73 1L 00 nn pp qq 00 00 00 00 00 00 FF	L: Line Number 0~0xA nn: H-position 0~0x1F pp: Color 0:WHT 1:YEL 2:MAG 3:RED qq: Blink 0:Not blink 1:Blinks																																																																																																																																				
	Title Set2	8x 01 04 73 2L mm nn pp qq rr ss tt uu vv ww FF	L: Line Number, mnpqrstuvw: Setting of characters (1 to 10)																																																																																																																																				
	Title Set3	8x 01 04 73 3L mm nn pp qq rr ss tt uu vv ww FF	L: Line Number, mnpqrstuvw: Setting of characters (11 to 20)																																																																																																																																				
			<table border="1"> <tr><td>A</td><td>B</td><td>C</td><td>D</td><td>E</td><td>F</td><td>G</td><td>H</td><td>0x00,</td><td>0x01,</td><td>...</td><td>0x07</td></tr> <tr><td>I</td><td>J</td><td>K</td><td>L</td><td>M</td><td>N</td><td>O</td><td>P</td><td>0x08,</td><td>0x09,</td><td>...</td><td>0x0f</td></tr> <tr><td>Q</td><td>R</td><td>S</td><td>T</td><td>U</td><td>V</td><td>W</td><td>X</td><td>0x10,</td><td>0x11,</td><td>...</td><td>0x17</td></tr> <tr><td>Y</td><td>Z</td><td>&</td><td></td><td>?</td><td>!</td><td>1</td><td>2</td><td>0x18,</td><td>0x19,</td><td>...</td><td>0x1f</td></tr> <tr><td>3</td><td>4</td><td>5</td><td>6</td><td>7</td><td>8</td><td>9</td><td>0</td><td>0x20,</td><td>0x21,</td><td>...</td><td>0x27</td></tr> <tr><td></td><td></td><td></td><td></td><td></td><td></td><td></td><td></td><td>0x28,</td><td>0x29,</td><td>...</td><td>0x2f</td></tr> <tr><td></td><td></td><td></td><td></td><td></td><td></td><td></td><td></td><td>0x30,</td><td>0x31,</td><td>...</td><td>0x37</td></tr> <tr><td></td><td></td><td></td><td></td><td></td><td></td><td></td><td></td><td>0x38,</td><td>0x39,</td><td>...</td><td>0x3f</td></tr> <tr><td></td><td></td><td></td><td></td><td></td><td></td><td></td><td></td><td>0x40,</td><td>0x41,</td><td>...</td><td>0x47</td></tr> <tr><td></td><td>"</td><td>:</td><td>'</td><td>.</td><td>,</td><td>/</td><td>-</td><td>0x48,</td><td>0x49,</td><td>...</td><td>0x4f</td></tr> <tr><td></td><td></td><td></td><td></td><td></td><td></td><td></td><td></td><td>0x50,</td><td>0x51,</td><td>...</td><td>0x57</td></tr> </table>	A	B	C	D	E	F	G	H	0x00,	0x01,	...	0x07	I	J	K	L	M	N	O	P	0x08,	0x09,	...	0x0f	Q	R	S	T	U	V	W	X	0x10,	0x11,	...	0x17	Y	Z	&		?	!	1	2	0x18,	0x19,	...	0x1f	3	4	5	6	7	8	9	0	0x20,	0x21,	...	0x27									0x28,	0x29,	...	0x2f									0x30,	0x31,	...	0x37									0x38,	0x39,	...	0x3f									0x40,	0x41,	...	0x47		"	:	'	.	,	/	-	0x48,	0x49,	...	0x4f									0x50,	0x51,	...	0x57
	A	B	C	D	E	F	G	H	0x00,	0x01,	...	0x07																																																																																																																											
	I	J	K	L	M	N	O	P	0x08,	0x09,	...	0x0f																																																																																																																											
	Q	R	S	T	U	V	W	X	0x10,	0x11,	...	0x17																																																																																																																											
	Y	Z	&		?	!	1	2	0x18,	0x19,	...	0x1f																																																																																																																											
	3	4	5	6	7	8	9	0	0x20,	0x21,	...	0x27																																																																																																																											
									0x28,	0x29,	...	0x2f																																																																																																																											
								0x30,	0x31,	...	0x37																																																																																																																												
								0x38,	0x39,	...	0x3f																																																																																																																												
								0x40,	0x41,	...	0x47																																																																																																																												
	"	:	'	.	,	/	-	0x48,	0x49,	...	0x4f																																																																																																																												
								0x50,	0x51,	...	0x57																																																																																																																												
Title Clear	8x 01 04 74 1p FF	Title Setting clear (p: 0 to a, f= all lines)																																																																																																																																					
On	8x 01 04 74 2p FF	Title display On/Off (0 to a, f= all lines)																																																																																																																																					
Off	8x 01 04 74 3p FF																																																																																																																																						



Command Set

Command Set	Command	Packet	Comments
CAM_Mute	On	8x 01 04 75 02 FF	Muting ON/OFF
	Off	8x 01 04 75 03 FF	
	On/Off	8x 01 04 75 10 FF	
	SetMask	8x 01 04 76 mm nn 0r 0r 0s 0s FF	mm: Mask Settings nn: 00-Modify, 01-New rr: W ss: H
	Display	8x 01 04 77 pp pp pp pp FF	Mask Display ON/OFF pp pp pp pp: Mask Settings (0: OFF, 1: ON)
	SetMaskColor	8x 01 04 78 pp pp pp pp qq rr FF	pp pp pp pp: Mask Color Settings qq: Color Setting when 0 is selected rr: Color Setting when 1 is selected
	CAM_PrivacyZone	SetPanTiltAngle	8x 01 04 79 0p 0p 0p 0q 0q 0q FF
SetPTZMask		8x 01 04 7B mm 0p 0p 0p 0q 0q 0q 0r 0r 0r 0r FF	Pan/Tilt/Zoom Settings for Mask ppp: Pan 0~0xFFFF qqq: Tilt 0~0xFFFF rrr: Zoom pos 0~0x4000
Non_InterlockMask		8x 01 04 6F mm 0p 0p 0q 0q 0r 0r 0s 0s FF	mm: Non_Interlock Mask Settings pp: X, q: Y, rr: W, ss: H
GridOn		8x 01 04 7C 02 FF	Grid Display ON/OFF
GridOff		8x 01 04 7C 03 FF	Grid/Center Line Display Off
CenterLineOn		8x 01 04 7C 04 FF	Center Line Display On
CAM_IDWrite			8x 01 04 22 0p 0q 0r 0s FF
CAM_Alarm	On	8x 01 04 6B 02 FF	Alarm ON/OFF
	Off	8x 01 04 6B 03 FF	



Command Set

Command Set	Command	Packet	Comments
CAM_MD	On	8x 01 04 1B 02 FF	Motion Detection On/Off
	Off	8x 01 04 1B 03 FF	
	Function Set	8x 01 04 1C 0m 0n 0p 0q 0r 0s FF	m: Display mode 0-Off 1-On n: Detection Frame Set bit0-Frame0 bit1-Frame1 bit2-Frame2 bit3-Frame3 pq: Threshold Level (00 to 0x14) rs: Interval Time set (00 to 0xF)
	Window Set	8x 01 04 1D 0m pp qq rr ss FF	m: Select Detection Frame (0, 1, 2, 3) pp: Start Horizontal Position (00 to 0x3C) qq: Start Vertical Position (00 to 0x28) rr: Stop Horizontal Position (01 to 0x3C) ss: Stop Vertical Position (01 to 0x28)
	Alarm (Reply)	y0 07 04 1B 0p FF	p: Detection Frame Number
CAM_Continuous ZoomPosReply	On	8x 01 04 69 02 FF	ZoomPosition data Continuous Output On/Off
	Off (Reply)	8x 01 04 69 03 FF y0 07 04 69 0p 0p 0q 0q 0q 0q FF	pp: D-Zoom Position * 00: When Zoom Mode is Combine qqqq: Zoom Position
CAM_ZoomPosRe- plyIntervalTimeSet		8x 01 04 6A 00 00 0p 0p FF	pp: Interval Time [Vertical timing]
CAM_Continuous FocusPosReply	On	8x 01 04 16 02 FF	FocusPosition data Continuous Output On/Off
	Off (Reply)	8x 01 04 16 03 FF y0 07 04 16 00 00 0p 0p 0p 0p FF	pppp: Focus Position
CAM_FosPosReply IntervalTimeSet		8x 01 04 6A 00 00 0p 0p FF	pp: Interval Time [Vertical timing]
CAM_Register Value		8x 01 04 24 mm 0p 0p FF	mm: Register No. (=00-7F) pp: Register Value (=00-7F)



Command Set

Command Set	Command	Packet	Comments
CAM_ ColorEnhance	Parameter Set	8x 01 04 20 mm nn pp qq rr FF	<p>mm: First byte from the top threshold value nn: Second byte from the top threshold value pp: Third byte from the top threshold value qq: Color specification for high-intensity rr: Color specification for low-intensity Range for mm, nn, and pp is 0 to F. Range for qq and rr is 0 to 8. Colors 0: Yellow, 1: Cyan, 2: Green, 3: White, 4: Magenta, 5: Red, 6: Blue, 7: Black, 8: Gray</p>
	On	8x 01 04 50 02 FF	Color Enhancement ON/OFF
	Off	8x 01 04 50 03 FF	
CAM_ ChromaSuppress		8x 01 04 5F pp FF	<p>pp: Chroma Suppress setting level 00: OFF 1 to 3: ON (3 levels). Effect increases as the level number increases.</p>
CAM_ColorGain	Direct	8x 01 04 49 00 00 00 0p FF	p: Color Gain setting 0h (60%) to Eh (200%)
CAM_ColorHue	Direct	8x 01 04 4F 00 00 00 0p FF	p: Color Hue setting 0h (- 14 degrees) ~ Eh (+14 degrees)
CAM_HLC		8x 01 04 14 0p 0q FF	<p>p: HLC level (0: OFF, 1: ON) q: HLC mask level (0 to F: from low to high level)</p>
CAM_Menu		8x 01 06 06 pp FF	<p>pp: 2-ON 3-OFF 0-BACK 11-UP 12-DOWN 14-LEFT 18-RIGHT</p>
CAM_Contrast	Direct	8x 01 7E 04 51 0p 0q FF	pq: 00 - 14h



Register Set

Command Set	Command	Packet	Comments
BaudRate		8x 01 04 24 00 00 0p FF	p: 0-9600 1-19200 2-38400 3-115200
Monitoring Mode		8x 01 04 24 72 0p 0p FF	pp: 1-1080i@59.94 2-1080i@60 3- 4-1080i@50 5- 6-1080p@29.97 7-1080p@30 8-1080p@25 9-720p@59.94 A-720p@60 B- C-720p@50 D- E-720p@29.97 F-720p@30 10- 11-720p@25 12- 13-1080p@59.94 14-1080p@50 15-1080p@60
Output enable		8x 01 04 24 73 00 0p FF	p: 1-CVBS On, LVDS/SDI Off 2-LVDS video On, CVBS/SDI Off 3-LVDS & CVBS On, SDI Off 4-SDI video On, CVBS//LVDS Off 5-SDI & CVBS On, LVDS Off 6-SDI & LVDS On CVBS Off 7-SDI & LVDS & CVBS On
LVDS Mode		8x 01 04 24 74 00 0p FF	p: 0-LVDS Single output 1-Dual Output

**Register Set**

Command Set	Command	Packet	Comments
Key Input enable		8x 01 04 24 70 00 0p FF	p: 0-Key input disable 1-enable
Wide limit		8x 01 04 24 50 0p 0p FF	pp: 0~FF refer Table
Tele limit		8x 01 04 24 51 0p 0p FF	pp: 0~FF refer Table
D-Zoom Max		8x 01 04 24 52 0p 0p FF	pp: Max D-zoom ratio = 256/ (256-pp)
Stable Zoom		8x 01 04 24 53 00 0p FF	p: 0-OFF 1-ON
Focus Trace		8x 01 04 24 54 00 0p FF	p: 0-OFF 1-ON
Focus Offset		8x 01 04 24 55 0p 0p FF	pp: 0-FF
Auto Slow Shutter Limit		8x 01 04 24 59 00 0p FF	p: 1-1/30 2-1/15 3-1/8 4-1/4 5-1/2 6-1/1
AF_InOutdoor		8x 01 04 24 4B 00 0p FF	p: 0-AF Indoor Mode 1-AF Outdoor Mode



Inquiry Command

Inquiry Command	Command Packet	Inquiry Packet	Comments
CAM_PowerInq	8x 09 04 00 FF	y0 50 02 FF	On
		y0 50 03 FF	Off(Standby)
CAM_ZoomPosInq	8x 09 04 47 FF	y0 50 0p 0q 0r 0s FF	pqrs: Zoom Position (refer Table)
CAM_DZoomModelInq	8x 09 04 06 FF	y0 50 02 FF	D-Zoom On
		y0 50 03 FF	D-Zoom Off
CAM_Dzoom C/SModelInq	8x 09 04 36 FF	y0 50 00 FF	Combine Mode
		y0 50 01 FF	Separate Mode
CAM_DZoomPosInq	8x 09 04 46 FF	y0 50 00 00 0p 0q FF	pq: D-Zoom Position
CAM_FocusModelInq	8x 09 04 38 FF	y0 50 02 FF	Auto Focus
		y0 50 03 FF	Manual Focus
CAM_FocusPosInq	8x 09 04 48 FF	y0 50 0p 0q 0r 0s FF	pqrs: Focus Position (0x1000 - 0xC000)
CAM_FocusNearLimitInq	8x 09 04 28 FF	y0 50 0p 0q 0r 0s FF	pqrs: Focus Near Limit Position
CAM_AFSensitivityInq	8x 09 04 58 FF	y0 50 02 FF	AF Sensitivity Normal
		y0 50 03 FF	AF Sensitivity Low
CAM_AFModelInq	8x 09 04 57 FF	y0 50 00 FF	Normal AF
		y0 50 01 FF	Interval AF
		y0 50 02 FF	Zoom Trigger AF
CAM_AFTimeSettingInq	8x 09 04 27 FF	y0 50 0p 0q 0r 0s FF	pq: Movement Time rs: Interval Time
CAM_IRCorrectionInq	8x 09 04 11 FF	y0 50 02 FF	Standard
		y0 50 03 FF	IR Light
CAM_WBModelInq	8x 09 04 35 FF	y0 50 00 FF	Auto
		y0 50 01 FF	InDoor
		y0 50 02 FF	OutDoor
		y0 50 03 FF	One Push WB
		y0 50 04 FF	ATW
		y0 50 05 FF	Manual
		y0 50 06 FF	Outdoor Auto
		y0 50 07 FF	Sodium Lamp Auto
CAM_RGainInq	8x 09 04 43 FF	y0 50 00 00 0p 0q FF	pq: R Gain
		y0 50 01 00 0p 0q FF	pq: B Gain



Inquiry Command

Inquiry Command	Command Packet	Inquiry Packet	Comments
CAM_AEModeInq	8x 09 04 39 FF	y0 50 00 FF	Full Auto
		y0 50 03 FF	Manual
		y0 50 0A FF	Shutter Priority
		y0 50 0B FF	Iris Priority
		y0 50 0D FF	Bright
CAM_SlowShutterModeInq	8x 09 04 5A FF	y0 50 02 FF	Auto
		y0 50 03 FF	Manual
CAM_ShutterPosInq	8x 09 04 4A FF	y0 50 00 00 0p 0q FF	pq: Shutter Position
CAM_IrisPosInq	8x 09 04 4B FF	y0 50 00 00 0p 0q FF	pq: Iris Position
CAM_GainPosInq	8x 09 04 4C FF	y0 50 00 00 0p 0q FF	pq: Gain Position
CAM_GainLimitInq	8x 09 04 2C FF	y0 50 0p FF	p: Gain Limit
CAM_BrightPosInq	8x 09 04 4D FF	y0 50 00 00 0p 0q FF	pq: Bright Position
CAM_ExpCompModeInq	8x 09 04 3E FF	y0 50 02 FF	On
		y0 50 03 FF	Off
CAM_ExpCompPosInq	8x 09 04 4E FF	y0 50 00 00 0p 0q FF	pq: ExpComp Position
CAM_BackLightModeInq	8x 09 04 33 FF	y0 50 02 FF	On
		y0 50 03 FF	Off
CAM_SpotAEModeInq	8x 09 04 59 FF	y0 50 02 FF	On
		y0 50 03 FF	Off
CAM_SpotAEPosInq	8x 09 04 29 FF	y0 50 0p 0q 0r 0s FF	pq: X position rs: Y position
CAM_AE_ResponseInq	8x 09 04 5D FF	y0 50 pp FF	pp: 01 to 0x20
CAM_WDModeInq	8x 09 04 3D FF	y0 50 02 FF	On Wide-D
		y0 50 03 FF	Off
		y0 50 06 FF	VE On
CAM_WDParameterInq	8x 09 04 2D FF	y0 50 0p 0p 0q 0r 0s 0t 0u 00 00 FF	q: Display brightness level (0: Dark to 6: Bright) r: Brightness compensation selection (0: Very dark, 1: Dark, 2: Standard, 3: Bright) s: Compensation level (0: Low, 1: Mid, 2: High) tu: 0



Inquiry Command

Inquiry Command	Command Packet	Inquiry Packet	Comments
CAM_DefogInq	8x 09 04 37 FF	y0 50 02 0p FF y0 50 03 00 FF	On p: Defog level (0: auto, 1: low, 2: mid, 3: high) Off
CAM_ApertureInq	8x 09 04 42 FF	y0 50 00 00 0p 0q FF	ppq: Aperture Gain
CAM_HRModelInq	8x 09 04 52 FF	y0 50 02 FF y0 50 03 FF	On (Hi-Resolution) Off
CAM_NRModelInq	8x 09 04 53 FF	y0 50 0p FF	Noise Reduction p: (0: OFF, level 1 to 3)
CAM_GammaInq	8x 09 04 5B FF	y0 50 0p FF	Gamma p: 0 to 4
CAM_GammaOffsetInq	8x 09 04 1E FF	y0 50 00 00 00 0s 0t 0u FF	s: Polarity offset (0 is plus, 1 is minus) tu: Offset s=0 (00h to 40h) Offset s=1 (00h to 10h)
CAM_HighSensitivityInq	8x 09 04 5E FF	y0 50 02 FF y0 50 03 FF	On Off
LR_ReverseModelInq	8x 09 04 61 FF	y0 50 02 FF y0 50 03 FF	On Off
FreezeModelInq	8x 09 04 62 FF	y0 50 02 FF y0 50 03 FF	On Off
PictureEffectModelInq	8x 09 04 63 FF	y0 50 00 FF y0 50 02 FF y0 50 04 FF	Off Neg.Art B&W
PictureFlipModelInq	8x 09 04 66 FF	y0 50 02 FF y0 50 03 FF	On Off
ICRModelInq	8x 09 04 01 FF	y0 50 02 FF y0 50 03 FF	On Off
AutoICRModelInq	8x 09 04 51 FF	y0 50 02 FF y0 50 03 FF	On Off
AutoICRThresholdInq	8x 09 04 21 FF	y0 50 00 00 0p 0q FF	ppq: ICR ON - OFF Threshold Level
AutoICRAAlarmReplyInq	8x 09 04 31 FF	y0 50 02 FF y0 50 03 FF	On Off
MemoryInq	8x 09 04 3F FF	y0 50 pp FF	pp: Memory number recalled last
MemSaveInq	8x 09 04 23 0X FF	y0 50 0p 0p 0q 0q FF	X: 00 to 07 (Address) ppqq: 0x0000 to 0xFFFF (Data)
DisplayModelInq	8x 09 04 15 FF (8x 09 06 06 FF)	y0 50 02 FF y0 50 03 FF	On Off



Inquiry Command

Inquiry Command	Command Packet	Inquiry Packet	Comments
StabilizerModelInq	8x 09 04 34 FF	y0 50 02 FF	On
		y0 50 03 FF	Off
		y0 50 00 FF	Hold
TitleDisplayModelInq	8x 09 04 74 FF	y0 50 02 FF	On
	(8x 09 06 06 FF)	y0 50 03 FF	Off
MuteModelInq	8x 09 04 75 FF	y0 50 02 FF	On
		y0 50 03 FF	Off
PrivacyDisplayInq	8x 09 04 77 FF	y0 50 pp pp pp pp FF	pp pp pp pp: Mask Display (0: OFF 1: ON)
PrivacyPanTiltInq	8x 09 04 79 FF	y0 50 0p 0p 0p 0q 0q 0q FF	ppp: Pan qqq: Tilt
PrivacyPTZInq	8x 09 04 7B mm FF	y0 50 0p 0p 0p 0q 0q 0q 0r 0r 0r 0r FF	mm: Mask Settings ppp: Pan qqq: Tilt rrrr: Zoom
PrivacyMonitorInq	8x 09 04 6F FF	y0 50 pp pp pp pp FF	pp pp pp pp: Mask is displayed now.
CAM_KeyLockInq	8x 09 04 17 FF	y0 50 00 FF	Off
		y0 50 02 FF	On
CAM_IDInq	8x 09 04 22 FF	y0 50 0p 0q 0r 0s FF	pqrs: Camera ID
CAM_VersionInq	8x 09 00 02 FF	y0 50 gg gg mn pq rs tu vw FF	gggg: Vender ID (00bc) mnpq: Model Code rstu: ROM version vw: Socket Number (=02)
AlarmInq	8x 09 04 6B FF	y0 50 02 FF	On
		y0 50 03 FF	Off
MDModelInq	8x 09 04 1B FF	y0 50 02 FF	On
		y0 50 03 FF	Off



Inquiry Command

Inquiry Command	Command Packet	Inquiry Packet	Comments
MDFunctionInq	8x 09 04 1C FF	y0 50 0m 0n 0p 0q 0r 0s FF	m: Display mode 0-Off 1-On n: Detection Frame Set bit0-Frame0 bit1-Frame1 bit2-Frame2 pq: Threshold Level (0 to 0x14) <i>rs: Interval Time set (0 to 0xF)</i>
MDWindowInq	8x 09 04 1D 0m FF	y0 50 pp qq rr ss FF	m: Select Detection Frame (0 1 2 3) pp: Start Horizontal Position (00 to 0x3C) qq: Start Vertical Position (00 to 0x28) rr: Stop Horizontal Position (01 to 0x3C) ss: Stop Vertical Position (01 to 0x28)
ContinuousZoomPos	8x 09 04 69 FF	y0 50 02 FF	On
ReplyModelInq		y0 50 03 FF	Off
ReplyIntervalTimeInq	8x 09 04 6A FF	y0 50 00 00 0p 0p FF	pp: Interval Time [VD timing]
ColorEnhanceInq	8x 09 04 20 FF	y0 50 mm nn pp qq rr FF	mm: First byte from the top threshold value nn: Second byte from the top threshold value pp: Third byte from the top threshold value qq: Color specification for high-intensity rr: Color specification for low-intensity 0: Yellow 1:Cyan 2:Green 3:White 4: Magenta 5:Red 6:Blue 7:Black 8:Gray
	8x 09 04 50 FF	y0 50 02 FF	On
		y0 50 03 FF	Off
ChromaSuppressInq	8x 09 04 5F FF	y0 50 pp FF	pp: Chroma Suppress setting level
ColorGainInq	8x 09 04 49 FF	y0 50 00 00 00 0p FF	p: Color Gain setting 0h (60%) to Eh (200%)
ColorHueInq	8x 09 04 4F FF	y0 50 00 00 00 0p FF	p: Color Hue setting 0h (? 14 degrees) ~ Eh (+ 14 degrees)
CAM_TempInq	8x 09 04 68 FF	y0 50 00 00 0p 0q FF	<i>pq : Current Temperature 0(0°C) ~ 0x7F(127 °C)</i>
CAM_HLCInq	8x 09 04 14 FF	y0 50 0p 0q FF	p: HLC level (0: OFF, 1: ON) q: HLC mask level (0 to F: from low to high level)
CAM_Menu	8x 09 06 06 FF	y0 50 0p FF	p: 2-ON 3-OFF
CAM_Contrast	8x 09 7E 04 51 FF	y0 50 0p 0q FF	pq: 00 ~ 14h



Inquiry Command : Register

Inquiry Command	Command Packet	Inquiry Packet	Comments
BaudRate	8x 09 04 24 00 FF	y0 50 00 0p FF	p: 0-9600 1-19200 2-38400 3-115200
Monitoring Mode	8x 09 04 24 72 FF	y0 50 0p 0p FF	pp: 1-1080i@59.94 2--1080i@60 3- 4-1080i@50 5- 6-1080p@29.97 7-1080p@30 8-1080p@25 9-720p@59.94 A-720p@60 B- C-720p@50 D- E-720p@29.97 F-720p@30 10- 11-720p@25 12- 13-1080p@59.94 14-1080p@50 15-1080p@60
Output enable	8x 09 04 24 73 FF	y0 50 00 0p FF	p: 1-CVBS On, LVDS/SDI Off 2-LVDS video On, CVBS/SDI Off 3-LVDS & CVBS On, SDI Off 4-SDI video On, CVBS//LVDS Off 5-SDI & CVBS On, LVDS Off 6-SDI & LVDS On CVBS Off 7-SDI & LVDS & CVBS On
LVDS Mode	8x 09 04 24 74 FF	y0 50 00 0p FF	p: 0-LVDS Single output 1-Dual output

**Inquiry Command : Register**

Inquiry Command	Command Packet	Inquiry Packet	Comments
Key Input enable	8x 09 04 24 70 FF	y0 50 00 0p FF	p: 0-Key input disable 1-enable
Wide limit	8x 09 04 24 50 FF	y0 50 0p 0p FF	pp: 0~FF refer Table
Tele limit	8x 09 04 24 51 FF	y0 50 0p 0p FF	pp: 0~FF refer Table
E-Zoom Max	8x 09 04 24 52 FF	y0 50 0p 0p FF	pp: Max D-zoom ratio = 256/ (256-pp)
Stable Zoom	8x 09 04 24 53 FF	y0 50 00 0p FF	p: 0-OFF 1-ON
Focus Trace	8x 09 04 24 54 FF	y0 50 00 0p FF	p: 0-OFF 1-ON
Focus Offset	8x 09 04 24 55 FF	y0 50 00 pp FF	pp: 0-FF
Auto Slow Shutter Limit	8x 09 04 24 59 FF	y0 50 00 0p FF	p: 1-1/30 2-1/15 3-1/8 4-1/4 5-1/2 6-1/1
AF_InOutdoor	8x 09 04 24 4B FF	y0 50 00 0p FF	p: 0-AF Indoor Mode 1-AF Outdoor Mode



Block Inquiry Command

Inquiry Command	Command Packet	Inquiry Packet	Comments
Lens Control System Inquiry	8x 09 7E 7E 00 FF	y0 50 0p 0p 0p 0p 0q 0q 0r 0r 0r 0r 00 hh 0m FF	<p>pppp: Zoom position</p> <p>qq: Near limit 0-30Cm, 1-1M, 2-1.5M, 3-2M, 4-3M, 5-5M, 6-10M</p> <p>rrrr: Focus position</p> <p>hh: [5]DzoomMode 0-combine 1-seperate [4:3] 0-Nor 1-Interval 2-ztrg [2]AF sensitivity 0-slow 1-Nor [1]Dzoom 0-off 1-on [0]FocusMode 0-Manual 1-Auto</p> <p>m: [3]Low contrast detection 0-no 1-yes</p> <p>[2]Camera memory recall 0-stopped 1-executing [1]Focus command 0-stopped 1-executing [0]Zoom command 0-stopped 1-executing</p>
	8x 09 7E 7E 01 FF	y0 50 0p 0p 0q 0q 0r 0s 0t hh mm nn 0u vv 0w FF	<p>pp: Rgain</p> <p>qq: Bgain</p> <p>r: WB mode</p> <p>s: Aperture gain</p> <p>t: Exposue Mode</p> <p>hh: [5]High resolution 0-off 1-on [4]Wide-D 0-off 1-other than off [3]Spot AE 0-off 1-on [2]Back Light 0-off 1-on [1]Exposure comp. 0-off 1-on [0]slow shutter 0-Manual 1-Auto</p> <p>mm: Shutter position</p> <p>nn: Iris position</p> <p>u: Gain position</p> <p>vv: Bright position</p> <p>w: Exposure Comp. position</p>



Block Inquiry Command

Inquiry Command	Command Packet	Inquiry Packet	Comments
			p: [3]Auto ICR alarm 0-off 1-on [2]Auto ICR 0-off 1-on [1]0 [0]power 0-off 1-on
			qq: [6]Stabilizer 0-off 1-on [5]Stabilizer Hold 0-off 1-Hold [4]ICR 0-off 1-on [3]Freeze 0-off 1-on [2]LR Reverse 0-off 1-on
			rr: [5]Privacy zone 0-off 1-on
	8x 09 7E 7E 02 FF	y0 50 0p qq rr 0s 00 00 0t 0t 0t 0t hh 00 00 FF	[4]Mute 0-off 1-on [3]Title display 0-off 1-on [2]Display 0-off 1-on
			s: Picture Effect Mode [2]B&W 0-off1-on [1]Neg.Art 0-off1-on
			ttt: Cam ID
			hh: [4]Memory 0-not provided 1-provided [3]0 [2]ICR 0-not provided 1-provided [1]Stabilizer 0-Not provided 1-Provided [0]0-1/60,1/30 1-1/50,1/25



Block Inquiry Command

Inquiry Command	Command Packet	Inquiry Packet	Comments
			<p>pp: Dzoom position</p> <p>qq: AF activation time</p> <p>rr: AF Interval time</p> <p>s: SpotAE position X</p> <p>t: SpotAE position Y</p> <p>u: [2]MD 0-off 1-on</p> <p>[1]Alarm 0-off 1-on</p> <p>[0]flip 0-off 1-on</p>
	8x 09 7E 7E 03 FF	y0 50 0p 0p 0q 0q 0r 0r 0s 0t 0u vv hh mm nn FF	<p>vv: [6:3]color gain</p> <p>[2]Advanced privacy 0-not provided</p> <p>[1]Alarm 1- provided</p> <p>[0]flip 1- provided</p> <p>hh: AE response</p> <p>mm: [6:4]Gamma</p> <p>[3]High Sensitivity mode 0-off 1-on</p> <p>[2:0]NR level</p> <p>nn: [6:4]Chroma suppression</p> <p>[3:0]Gain limit</p>
	8x 09 7E 7E 04 FF	y0 50 0p 0q 0r 0s 0t 0u 0v 00 00 00 00 00 00 FF	<p>p: WideD mode 0-off 1-on</p> <p>2-VE On</p> <p>r: Display brightness level setting</p> <p>0: Dark to 6: Brightt</p> <p>s: Brightness compensation selection</p> <p>0: Very dark 1: Dark 2: Standard 3: Bright</p> <p>t: Compensation level 0: Low 1: Mid 2: High</p> <p>u: [0]Defog 0-off 1-on</p> <p>v: [1:0] Defog Level 0:auto 1:low 2:mid 3:high</p>
	8x 09 7E 7E 05 FF	y0 50 0p 00 00 00 00 00 00 00 00 00 00 00 FF	<p>p: Color Hue</p>

**TABLE.****Shutter Speed**

Value	NTSC	PAL
15	1/10000 (1/20000)	1/10000 (1/20000)
14	1/6000 (1/12000)	1/6000 (1/12000)
13	1/4000 (1/8000)	1/3500 (1/7000)
12	1/3000 (1/6000)	1/2500 (1/5000)
11	1/2000 (1/4000)	1/1750 (1/3500)
10	1/1500 (1/3000)	1/1250 (1/2500)
0F	1/1000 (1/2000)	1/1000 (1/2000)
0E	1/725 (1/1450)	1/600 (1/1200)
0D	1/500 (1/1000)	1/425 (1/850)
0C	1/350 (1/700)	1/300 (1/600)
0B	1/250 (1/500)	1/215 (1/430)
0A	1/180 (1/360)	1/150 (1/300)
09	1/125 (1/250)	1/120 (1/240)
08	1/100 (1/200)	1/100 (1/200)
07	1/90 (1/180)	1/75 (1/150)
06	1/60 (1/120)	1/50 (1/100)
05	1/30 (1/60)	1/25 (1/50)
04	1/15 (1/30)	1/12 (1/25)
03	1/8 (1/15)	1/6 (1/12)
02	1/4 (1/8)	1/3 (1/6)
01	1/2 (1/4)	1/2 (1/3)
00	1/1 (1/2)	1/1 (1/2)

IRIS

Value	F no.
11	F1.5
10	F2
0F	F2.4
0E	F2.8
0D	F3.4
0C	F4
0B	F4.8
0A	F5.6
09	F6.8
08	F8
07	F9.6
06	F11
05	F14
00	CLOSE



Gain

Value	dB	
0F	+50 dB	
0E	+47 dB	
0D	+43 dB	
0C	+40 dB	
0B	+37 dB	
0A	+33 dB	
09	+30 dB	
08	+27 dB	
07	+23 dB	
06	+20 dB	
05	+17 dB	
04	+13 dB	
03	+10 dB	
02	+7 dB	
01	0 dB	
00	0 dB	

Gain Limit

Value	dB	
0F	+50 dB	
0E	+47 dB	
0D	+43 dB	
0C	+40 dB	
0B	+37 dB	
0A	+33 dB	
09	+30 dB	
08	+27 dB	
07	+23 dB	
06	+20 dB	
05	+17 dB	
04	+13 dB	

Brightness

Value	IRIS	GAIN
1F	F1.6	+50 dB
1E	F1.6	+47 dB
1D	F1.6	+43 dB
1C	F1.6	+40 dB
1B	F1.6	+37 dB
1A	F1.6	+33 dB
19	F1.6	+30 dB
18	F1.6	+27 dB
17	F1.6	+23 dB
16	F1.6	+20 dB
15	F1.6	+17 dB
14	F1.6	+13 dB
13	F1.6	+10 dB
12	F1.6	+6 dB
11	F1.6	0 dB
10	F2	0 dB
0F	F2.4	0 dB
0E	F2.8	0 dB
0D	F3.4	0 dB
0C	F4	0 dB
0B	F4.8	0 dB
0A	F5.6	0 dB
09	F6.8	0 dB
08	F8	0 dB
07	F9.6	0 dB
06	F11	0 dB
05	F14	0 dB
00	CLOSE	0 dB



Zoom Ratio	Zoom Ratio	Position Data		Zoom Ratio	Position Data
Optical Zoom	×1	0000		×21	3E68
	×2	1538		×22	3EBD
	×3	1F29		×23	3EFE
	×4	253E		×24	3F3E
	×5	2985		×25	3F69
	×6	2CBF		×26	3F94
	×7	2F64		×27	3FBF
	×8	3192		×28	3FD5
	×9	3375		×29	3FEA
	×10	3518		×30	4000
	×11	3690			
	×12	37DD			
	×13	3909			
	×14	3A16			
	×15	3B02			
	×16	3BCE			
	×17	3C84			
	×18	3D1B			
	×19	3D9C			
	×20	3E07			
Digital Zoom	×1	4000			
	×2	6000			
	×3	6A80			
	×4	7000			
	×5	7300			
	×6	7540			
	×7	76C0			
	×8	7800			
	×9	78C0			
	×10	7980			
	×11	7A00			
	×12	7AC0			



Limit Setting Value	Wide Limit	Tele Limit
00	x1.0	X30
03		X29
06		X28
09		X27
0C		X26
10	X2	X25
18		X24
20	X3	X23
28		X22
30	X4	X21
38		X20
40	X5	X19
50	X6	X18
60	X7	X17
70	X8	X16
80	X9	X15
90	X10	X14
A0	X11	X13
B0	X12	
C0	X13	X12
D0	X14	X11
E0	X15	
F0	X16	X10

Compliments of STEMMER IMAGING USA
stemmer-imagingusa.com



APPENDIX B

PELCO Protocol

PELCO "D" Byte Format

Command Message

Command	Data						
	BYTE 1	BYTE 2	BYTE 3	BYTE 4	BYTE 5	BYTE 6	BYTE 7
Zoom Tele	0xFF	CamID	0x00	0x20	0x00	0x00	Checksum
Zoom Wide	0xFF	CamID	0x00	0x40	0x00	0x00	Checksum
Focus Near	0xFF	CamID	0x01	0x00	0x00	0x00	Checksum
Focus Far	0xFF	CamID	0x00	0x80	0x00	0x00	Checksum
Up(Menu)	0xFF	CamID	0x00	0x08	0x00	0x00	Checksum
Down(Menu)	0xFF	CamID	0x00	0x10	0x00	0x00	Checksum
Left(Menu)	0xFF	CamID	0x00	0x04	0x00	0x00	Checksum
Right(Menu)	0xFF	CamID	0x00	0x02	0x00	0x00	Checksum
Menu On/Off	0xFF	CamID	0x40	0x00	0x00	0x00	Checksum
STOP	0xFF	CamID	0x00	0x00	****	****	Checksum

Pelco Keyboard (95+PATTERN)

Function	Menu On / Off						
	BYTE 1	BYTE 2	BYTE 3	BYTE 4	BYTE 5	BYTE 6	BYTE 7
MSG	0xFF	CamID	0x00	0x23	0x00	0x5F	Checksum

V/D Keyboard (Set Preset +98)

Function	Menu On / Off						
	BYTE 1	BYTE 2	BYTE 3	BYTE 4	BYTE 5	BYTE 6	BYTE 7
MSG	0xFF	CamID	0x00	0x03	0x00	0x62	Checksum