

HXC20

Facts and Data

Digital Monochrome Matrix Camera, 2 Megapixel, CameraLink®

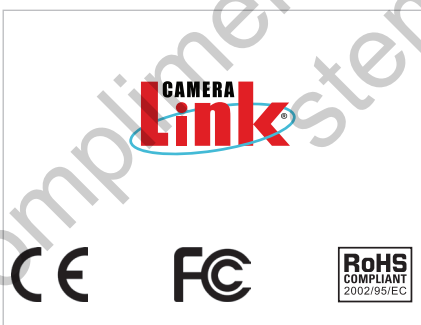
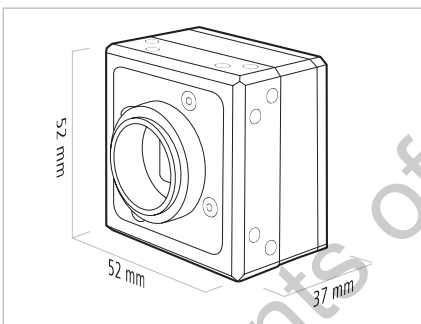

Baumer Optronic GmbH
 Badstrasse 30
 DE-01454 Radeberg, Germany
 Phone +49 (0)3528 4386 0
 Fax +49 (0)3528 4386 86
 sales@baumeroptronic.com
 www.baumer.com/cameras

Sensor Information

| | |
|-------------------|----------------------------|
| Model Name | CMOS CMV-2000 |
| Type | 2/3" progressive scan CMOS |
| Native Resolution | 2048 × 1088 pixels |
| Exposure Time | 20 µsec ... 1 sec |

Acquisition Formats

| | | | |
|---------------|---|--------------------|----------------|
| Image Formats | Full Frame | 2048 × 1088 pixels | max. 337.0 fps |
| | Binning 2x1 | 1024 × 1088 pixels | max. 337.0 fps |
| | Subsampling 2x2 | 1024 × 544 pixels | max. 664.0 fps |
| Pixel Formats | Mono8, Mono10, Mono12 | | |
| Partial Scan | True Partial Scan, Region of Interest (ROI) arbitrary | | |

Image Pre-processing

| | |
|-----------------|------------------------|
| Analog Controls | Offset (0 ... 255 LSB) |
| Color Modes | Mono |

Camera Features

| | |
|---------------------------|--|
| Internal Buffer | 256 MBytes (max. 110 images) |
| Synchronization | Free running, Trigger |
| Trigger Sources | Hardware, Software, FrameGrabber |
| Trigger Delay | 0 ... 2 sec, Tracking and buffering of up to 512 trigger signals |
| Sequencer | Automated control for series of images using different sets of parameters |
| Sequencer Characteristics | up to 128 sets of parameters, up to 4 billion loop passes, up to 4 billion repetitions of sets of parameters, up to 4 billion images per trigger event |
| Sequencer Parameters | Exposure Time, Gain Factor, Output |
| Digital I/Os | 3 input lines (with Debouncer), 3 output lines |

Interfaces and Connectors

| | |
|-------------------|--|
| Data Interface | CameraLink® Base, Medium und Full Connector: 2x Standard SDR26 (Mini CL) |
| Process Interface | M8 / 8 pins |
| Power Interface | M8 / 3 pins |

Mechanical Data

| | |
|------------|------------------|
| Housing | Aluminum, IP40 |
| Lens Mount | C-Mount, F-Mount |
| Dimensions | 52 × 52 × 37 mm |
| Weight | 185 g |

Electrical Data

| | |
|-------------------|-------------------|
| Power Supply | 9.6 ... 30 V DC |
| Power Consumption | approx. 5.5 Watts |

Environmental Data

| | |
|-----------------------|---------------------------------------|
| Operating Temperature | +5 °C ... +60 °C (+41 °F ... +131 °F) |
| Humidity | 10% ... 90% non condensing |