

GEN*i*CAM



Article Overview

Compute System (System on Module, SoM)	NVIDIA® Jetson Nano™
Camera Type	GeniCam standard, attached over USB3
Image Sensor	Sony IMX265 Gen2
Image Signal Processor (ISP)	FPGA based, suitable for machine vision
Hardware Trigger	FPGA based for high speed/accurate image triggering
LED/Flash Driver	FPGA based trigger for synchronisation at high speed, high power circuit, up to 2.5A @ 48 V
OS	Linux® based on Ubuntu 18.04 and NVIDIA® L4T 32.4.4
Installed Software	NVIDIA® Jetpack 4.4.1, Baumer GAPI & neoAPI SDK's, Camera Explorer preinstalled
Freely Programmable	All operating system and software can be customized as required. Compatible with many Linux® standard software products and programming languages
OS/FW Version	1.1

Computing Information

SoM Model	NVIDIA® Jetson™ Nano
CPU	NVIDIA® ARM® Cortex A57 MPCore
CPU Instruction Set	NEON Technology
CPU Cores	4
CPU L1 Cache	48 KB
CPU L2 Cache	2 MB
CPU L3 Cache	-
CPU Max. Frequency	1.43 GHz
GPU	NVIDIA® Maxwell
GPU Interfaces	OpenGL 4.6, OpenGL ES 3.2, Vulkan 1.1, CUDA
GPU Cores	128 NVIDIA® CUDA Cores
GPU Max. Frequency	921 MHz
Deep Learning Accelerator (DLA)	-
Memory	Dual Channel, 4ch x 16-bit LPDDR4
Memory Capacity	4 GB
Memory Max. Frequency	1600 MHz
Memory Peak Bandwidth	25.6 GB/s
eMMC Storage Type	eMMC 5.1 Flash Storage
eMMC Storage Capacity	16 GB (shared with the OS and installed software), extendable via SD-card

Sensor Graph: Relative Response

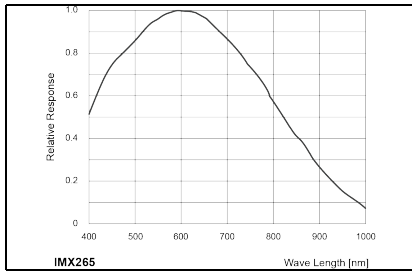

External Interfaces

Networking	10/100/1000 BASE-T Ethernet, Media Access Controller (MAC) over M12 connector
USB	2 x USB3 (max. bandwidth 5 GB, shared with camera, max. 900mA @ 5 V), 2 x MicroUSB for debug and recovery
HDMI	HDMI 2.0a/b (up to 6Gbps), maximum resolution 3840 x 2160 at 60Hz (up to 24bpp)
Inputs	1 x Hardware Trigger, opto-decoupled 1 x Input to NVIDIA SoM, opto-decoupled
Outputs	3 x PWM 48V/2.5A, 1 x synchronized for flash, 2 x non synchronized, opto-decoupled
UART	1 x RS232, Rx/Tx only

Camera Details

Sensor Model Name	Sony IMX265 Gen2
Sensor Type	1/1.8" progressive scan CMOS
Shutter	Global Shutter
Resolution	2048 x 1536 pixels
Scan Area	7.06 mm x 5.29 mm
Pixel Size	3.45 μ m x 3.45 μ m

Camera Data Quality

@ 20 °C, gain = 1, exposure time = 4 msec

Dark Noise (σ)	2 e- typical
Saturation	9500 e- typical
Dynamic Range	71 dB typical
SNR	40 dB typical
Quantum efficiency η	66% @ 536 nm typical
Firmware	Revision 3.0

Image Acquisition

Resolution	2048 px x 1536 px		
Interface Frame Rate (depends on used interface performance)	Format	Resolution	max. Frame Rate (@ Trigger Mode) ²⁾
	Full Frame	2048 x 1536	55 fps
	Binning 2x2	1024 x 768	55 fps
	Binning 2x1	1024 x 1536	55 fps
	Binning 1x2	2048 x 768	55 fps
Acquisition Frame Rate ¹⁾	55 fps $t_{readout} = 18$ msec (max. Res. Full Frame) @ 12 bit		
Pixel Formats	Mono8, Mono10, Mono12, Mono12p		
Partial Scan	True Partial Scan with increasing Frame Rate on Y direction, Region of Interest (ROI) arbitrary Width: minimum 16, increment 16 Height: minimum 1, increment 1		
Acquisition Frame Rate	Off or 0.01 ... 65535 Hz		
Acquisition Mode	Continuous, Single Frame and Multi Frame		
Acquisition Status	AcquisitionActive, AcquisitionTrigger Wait		
Exposure Mode	Timed		
Shutter Mode	Global		
Readout Mode	Overlapped, Sequential		

¹⁾ Sensor readout, different from pixel format ²⁾ depends on the used interface

Image Pre-Processing (FPGA-Based)

Analog Controls	Exposure Time (1 µsec ... 60 sec Step Size 1 µsec) Gain (0...48 dB), Offset (0 ... 255 LSB 12 bit)
Auto Function	ExposureAuto and GainAuto with BrightnessAutoPriority based on BrightnessAuto ROI
Gamma Correction	Gamma (0.1 ... 2 available if LUT is enabled)
LUT	Luminance (12 bit)
Color Models	Mono
Color Processing	-
Color Enhancement	-
Color Tolerance	-
Binning Horizontal	1 or 2
Binning Vertical	1 or 2
Fix Pattern Noise Correction	yes

Camera Process Synchronization

Trigger Mode	Off (Free Running), On (Trigger)
Trigger Overlap Type	Readout
Trigger Sources	Hardware (Line1), Software, Counter, End, All or Off fixed Trigger Delay out of t _{readout} : ¹⁾ 67 µsec @ 12 bit max. Trigger Delay during t _{readout} : ¹⁾ 73.7 µsec @ 12 bit
Trigger Delay	0 ... 2 sec, Tracking and buffering of up to 256 triggers
External Flash Sync	via Exposure Active t _{delay flash} ≤ 3 µsec, t _{duration} = t _{exposure}
Encoder Function	yes, via Counter and Trigger Source

Camera Digital I/Os

Lines	Input: Line 1, Output: Line 2, (Line 0/3 not usable)
Output Sources	Off, ExposureActive, Timer1, ReadoutActive, UserOutput 1-3 and TriggerReady
Line Debouncer	Low and high signal separately selectable Debouncing Time 0 ... 5 msec, Step Size: 1 µsec

USB 3 Vision® Features

Events Transmission via Asynchronous Message Channel	DeviceTemperatureStatusChanged, EventLost, ExposureEnd, ExposureStart, FrameEnd, FrameStart, FrameTransferSkipped, GigEVisionError, GigEVisionHeartbeatTimeOut, PrimaryApplicationSwitch, Line0..7 FallingEdge, Line0..7 RisingEdge, TransferBufferFull, TransferBufferReady, TriggerOverlapped, TriggerReady, TriggerSkipped
Frame Counter	up to 2 ³²
Payload Size	0 ... 6291680 Byte
Timestamp	64 bit, resolution in nsec, increment = 10
USB Vision	v1.0.1

¹⁾ Sensor readout, different from pixel format

Digital Input/Output

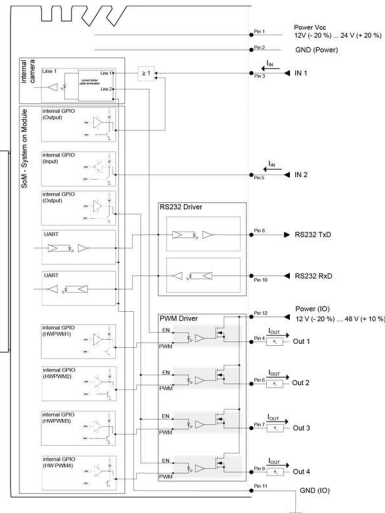

Trigger Mode: Start up time and valid Trigger

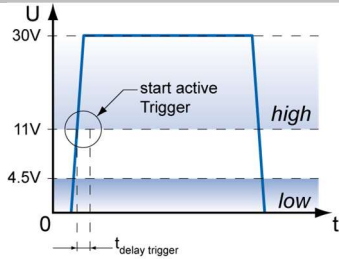

Pin Assignment Data Interface



Connector: M12 / 8-pin / x-coded (SACC-CI-M12FS-8CON-L180-10G)

Pin	Assignment	Pin	Cable color
1	MX1+	2	MX1-
3	MX2+	4	MX2-
5	MX4+	6	MX4-
7	MX3-	8	MX3+

Pin Assignment Process Interface

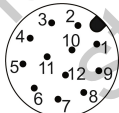

Connector: M12 / 12-pin / a-coded (SACC-CI-M12MS-12CON-L180)

Pin	Assignment	Cable color
1	Power Vcc	Brown
2	GND (Power VCC)	Blue
3	IN1 (Camera Line 1)	White
4	OUT1 (Camera Line 2)	Green
5	IN2	Pink
6	OUT2	Yellow
7	OUT3	Black
8	RS232 Tx/D	Grey
9	OUT4	Red
10	RS232 Rx/D	Violet
11	GND IO	Grey-Pink
12	Power IO	Red-Blue

Optical Data

Lens Mount C-Mount

Optical Filter -

Mechanical Data

Housing aluminum, hard anodized

Protection Class IP65/67 (with mounted USB/HDMI cover, lens tube and suitable M12 cables) IP30 without

Weight 640 g

Dimensions

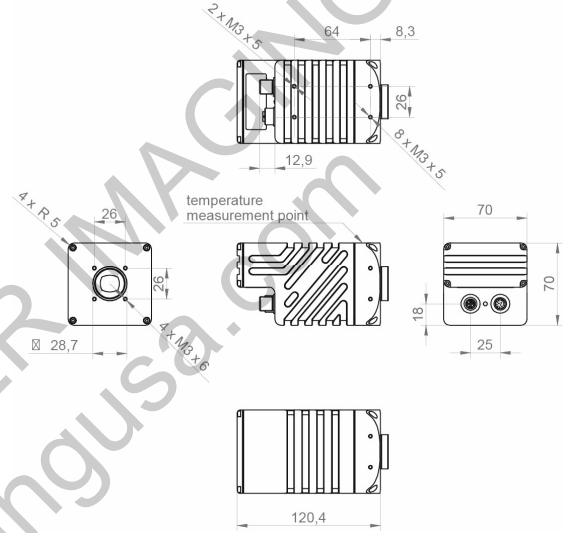

Environmental Data

Storage Temperature -10 °C ... + 70 °C

Operating Temperature *)

*) the maximum temperature for Sony sensor characteristics (sensor performance) are guaranteed up to 50 °C @ Measurement Point or up to 60 °C @ internal temperature sensor

Max. ambient temperature depending on use case:

	Mounted on 45x90 mm Aluminium Profil	Not mounted
Full power usage (CPU, GPU & Camera @ 100%)	53 °C	40 °C
Typical power usage (running a typical DNN & Camera)	56 °C	46 °C

0 °C ... +65 °C @ T = Measurement Point or
0 °C ... +73 °C @ internal Temperature Sensor

Int. Temperature Sensor yes, ±2 °C (typ) -40 °C ... 0°C, ±1 °C (typ) 0 °C ... +85 °C

Humidity 10 % ... 90 % non-condensing

Electrical Data

Power Supply VCC: 24 V DC ± 20%
I: 1100 mA

Power Consumption approx. 13.2 W @ 55 fps
(typical) (Factory Setting "Default")

Digital Input Opto-decoupled
U_{IN(low)} : 0.0 ... 4.5 VDC
U_{IN(high)} : 11.0 ... 30.0 VDC
I_{IN} : 3.0 ... 10.0 mA
min. Impulse Length: 2.0 µsec

Caution



* The General Purpose I/Os (GPIOs) are not potential-free and do not have an overrun cut-off. Incorrect wiring (overvoltage, undervoltage or voltage reversal) can lead to defects in the electronic system.
Ground loops are to be avoided and can lead to destruction of the device.

Electrical Data

Digital Output	Isolated, short-circuit protected
U _{ext} :	12 .. 48 V DC (Power IO) (See documentation for guidelines when using > 30 V)
I _{out} :	Continuously: max. 1.5 A PWM t _{on} max. 1s / Duration max. 40% max. 2.5 A (Max. current can be used on one output or as a sum of all outputs)

Conformity

Conformity	CE, RoHS, REACH
KC Registration No. / Date	- /
MTBF	53 years @ T = 45 °C / 36 years @ T = 60 °C T = Measurement Point

Camera GenICam™ Features

Timer	Timer Selector: Timer Selector: Timer 1 TimerTriggerSource: Line1, SoftwareTrigger, ExposureStart, ExposureEnd, FrameTransferSkipped, TriggerSkipped, Off TimerDelay: 0 µsec ... 2 sec, Step Size: 1 µsec TimerDuration: 4 µsec ... 2 sec, Step Size: 1 µsec
Counter	Counter Selector: Counter 1, Counter 2 CounterValue: 0 ... 65535 Counter Event Source: Counter1End or Counter2End, ExposureActive, FrameTransferSkipped, FrameTrigger, TriggerSkipped, Line0..3 and Off Counter Reset Source: Counter1End, Counter2End, Line0..3 and Off
Sequencer	Sequencer Characteristics: up to 128 sets, up to 4 possible pathes for triggered set transitions, 6 trigger sources: Counter1End, Counter2End, ExposureActive, Line0..3, ReadoutActive, Timer1End Sequencer Parameters for Exposure, Gain, Trigger, ROI and Output: ExposureTime, CounterDuration, CounterEventActivation, CounterEventSource, CounterResetSource, ExposureMode, ExposureTime, Gain, Height, OffsetX, OffsetY, TriggerMode, UserOutputValue, UserOutputValueAll, Width
User Sets	Factory Settings: UserSet0 (read only) Freely Programmable: UserSet1, UserSet2, UserSet3 Parameters: any user definable Parameter
Acquisition Abort	Delay up to 18 msec
Chunk Data	yes, Chunk Selector: Binning, BlackLevel, CounterValue, DeviceTemperature, ExposureTime, FrameID, Gain, Height, Image, ImageControl, LineStatusAll, OffsetX, OffsetY, PixelFormat, SequencerSetActive, Timestamp, Width
Device Temperature	InHouse Event generation for Normal to High, High to Exceeded and Exceeded to Normal Exceeded (no image transfer) = max. internal temperature sensor + 1 °C
Device Link Throughput Limit	yes, up to max. Device Link Speed
Custom Data	yes, 128 Byte
SFNC Version	v2.4

Camera Factory Settings after Start-Up

Trigger Mode	Off (Free Running)
Analog Controls	Exposure Time: 4 msec, Gain: 0 dB, Offset: 0
Pixel Format	Mono8
Partial Scan	Off
Acquisition Frame Rate	Off
Timer/Counter/Sequencer	Off
Defect Pixel Correction	On
Fixed Pattern Noise Correction	-
Digital Input	Line0, invert = false
Digital Output	Line3, invert = false, line source = Off
GPIO 1/2	Line1, Line2, invert = false, LineMode = Input
TriggerSource	All

Camera Partial Scan Framerates

@ FullFrame, min Exposure, Mono8 (monochrome camera) or BayerRG8 (color camera)

	Resolution	max. fps acquisition	max. fps interface ²⁾
Full HD	1920 x 1080	78	78
SXGA	1280 x 1024	82	82
HD720	1280 x 720	115	115
XGA	1024 x 768	108	108
SVGA	800 x 600	136	136
VGA	640 x 480	168	168
CIF	352 x 288	266	266
QVGA	320 x 240	312	312
QCIF	176 x 144	474	474
LineScan	2048 x 1024	82	82
	2048 x 512	158	158
	2048 x 256	295	295
	2048 x 128	519	519
	2048 x 64	838	838
	2048 x 32	1208	1208
	2048 x 16	1550	1550
	2048 x 8	1805	1805
	2048 x 4	1968	1968
	2048 x 2	2060	2060
	2048 x 1	2110	2110

²⁾ depends on the used interface